

No	Product Number	Product Name	ST	Qty	Rev. Date	No
1	01007-B96-030	ENGINE, GX390T2 SWD4		1		1
10	02901-B96-030	COVER, RECOIL		1		11
11	48911-B96-001	BOLT, SHOULDER 6 x 9S	M2B	3		12
14	02902-B96-000	COVER A, ENGINE		1		14
15	48905-B96-000	BOLT, SHOULDER 6 x 9	M0	1		15
16	48912-B96-000	BOLT, SHOULDER 8 x 14		1		16
19	09300-B96-000	COVER B COMP,ENGINE	H0	1		19
20	93100-0801617	BOLT, FLANGE 8 x 16		1		21
22	02700-B96-801	STAY L COMP, COVER	B2	1		31
23	-					33
24	93100-0601617	BOLT, FLANGE 6 x 16		2		32
25	-					34
26	08905-B96-800	STAY, HARNESS	B2	1		22
27	-					23
28	91314-11765	STRAP, CABLE 1-1765		2		29
30	03200-BA2-801	BASE COMP, ENGINE(1280	B2M	1	Δ 1 2025/12/01	25
31	94006-10410	NUT, FLANGE 10 x 1.25		5		26
32	91314-119P7	STRAP, CABLE 1-19P7		2		28
33	91382-0701701	CORRUGATE 7 x 170		1		38

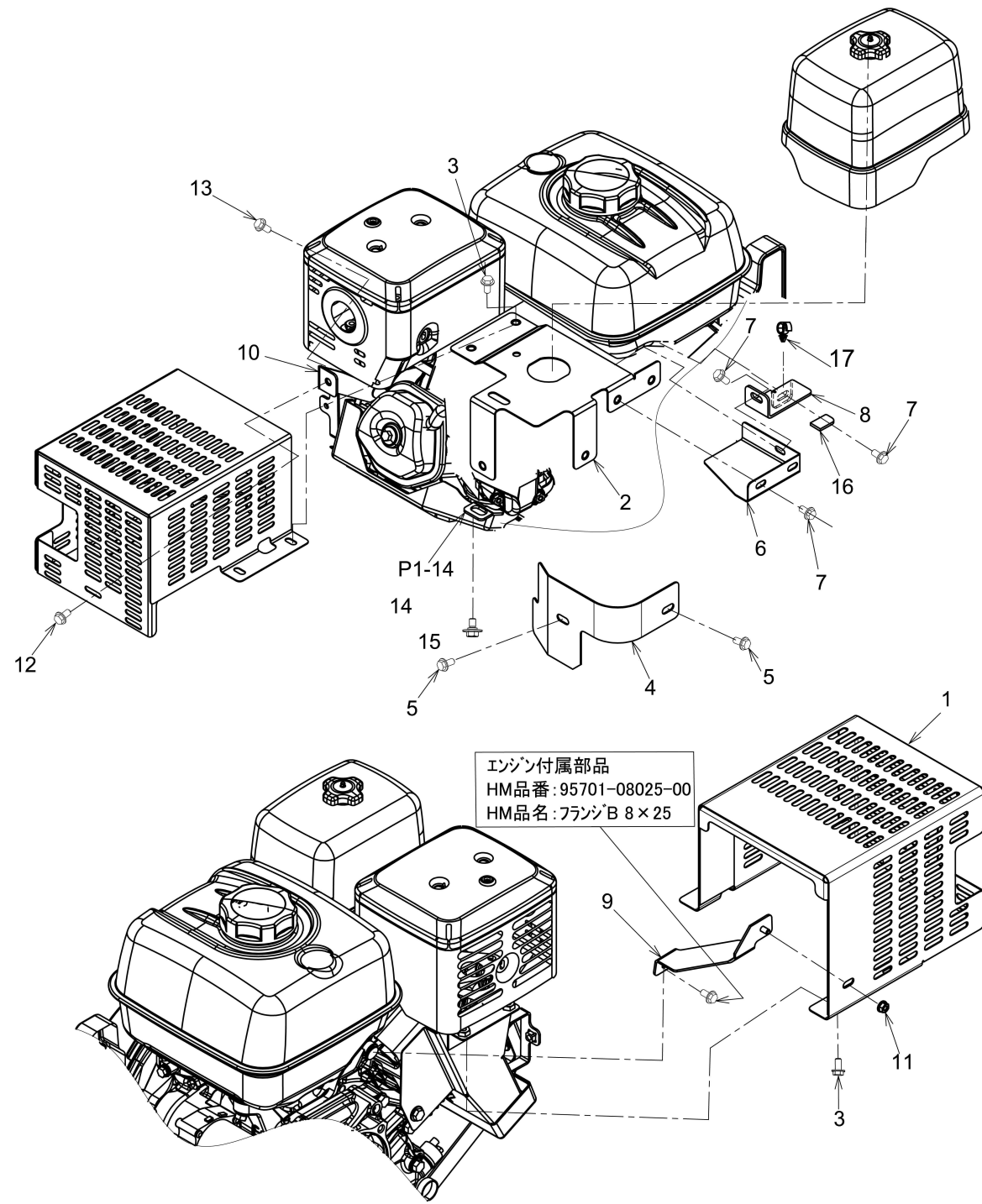

No	Product Number	Product Name	ST	Qty	Rev. Date	No
1	04100-B96-001	COVER COMP, MUFFLER	H0	1		35
2	04200-B96-800	BASE COMP, ENGINE COVER	B2	1		36
3	93100-0601217	BOLT, FLANGE 6 x 12		4		37
4	04902-B96-801	COVER, AIR CLEANER	B2	1		39
5	93100-0601017	BOLT, FLANGE 6 x 10		2		40
6	04600-B96-800	COVER COMP, UNDER	B2	1		41
7	93100-0601217	BOLT, FLANGE 6 x 12		4		42
8	05902-BA3-801	STAY, JOINT	B2	1		43
9	04400-B96-800	STAY A COMP, MUFFLER COVER	B2	1		44
10	04500-B96-801	STAY B COMP, MUFFLER COVER	B2	1		45
11	94002-06410	NUT, FLANGE 6		1		46
12	93100-0601217	BOLT, FLANGE 6 x 12		1		47
13	-					48
14	48913-B96-000	BOLT, SHOULDER 6 x 9L	M2B	1		49
16	-					51
17	91315-A3455	CLIP, CABLE A-3455		1		52
18	05600-BA3-800	PLATE COMP, ADJUST	B2	1		53
19	93100-0601217	BOLT, FLANGE 6 x 12		1		54

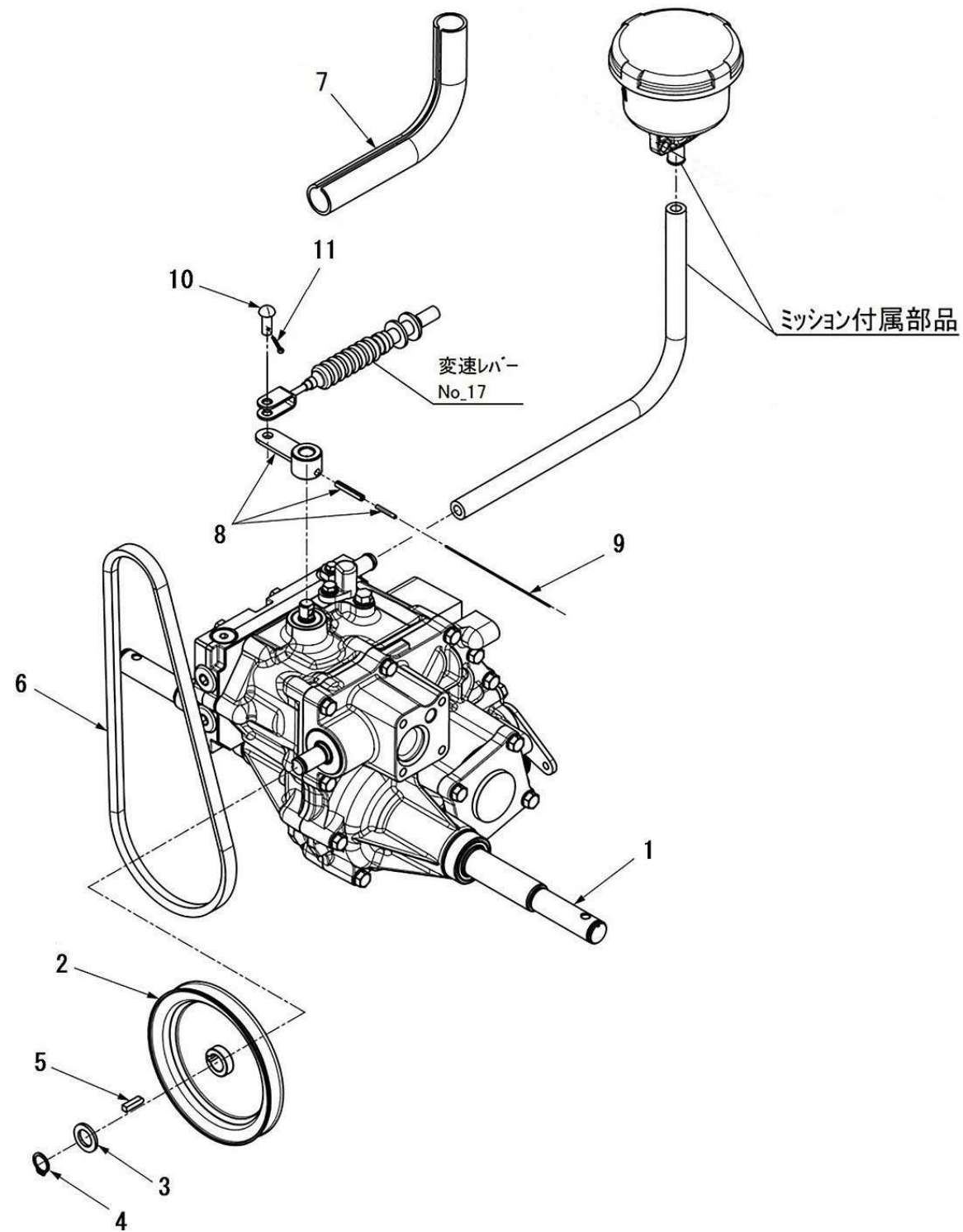

No	Product Number	Product Name	ST	Qty	Rev. Date	No
1	10001-B90-031	TRANSMISSION, SB-10SCS		1		1001
2	64200-B96-000	PULLEY COMP, HST	M1	1		1002
3	91251-1525231	WASHER, RD 15×25×2.3	M1	1		1003
4	94510-15080	CIRCLIP, EX 15		1		1004
5	97112-020141	KEY, 5×5×20SR		1		1005
6	64901-B96-000	BELT SA34, RED S II		1		1006
7	91382-2204001	CORRUGATE, 22×400		1		1007
8	10002-B90-000	LEVER KIT, HST		1		1011
9	75913-B18-000	WIRE, 1.2×100		1		1012
10	94330-0802510	PIN, 8×25		1		1013
11	94210-25150	PIN, SPLIT 2.5×15		1		1014
13	-					1134

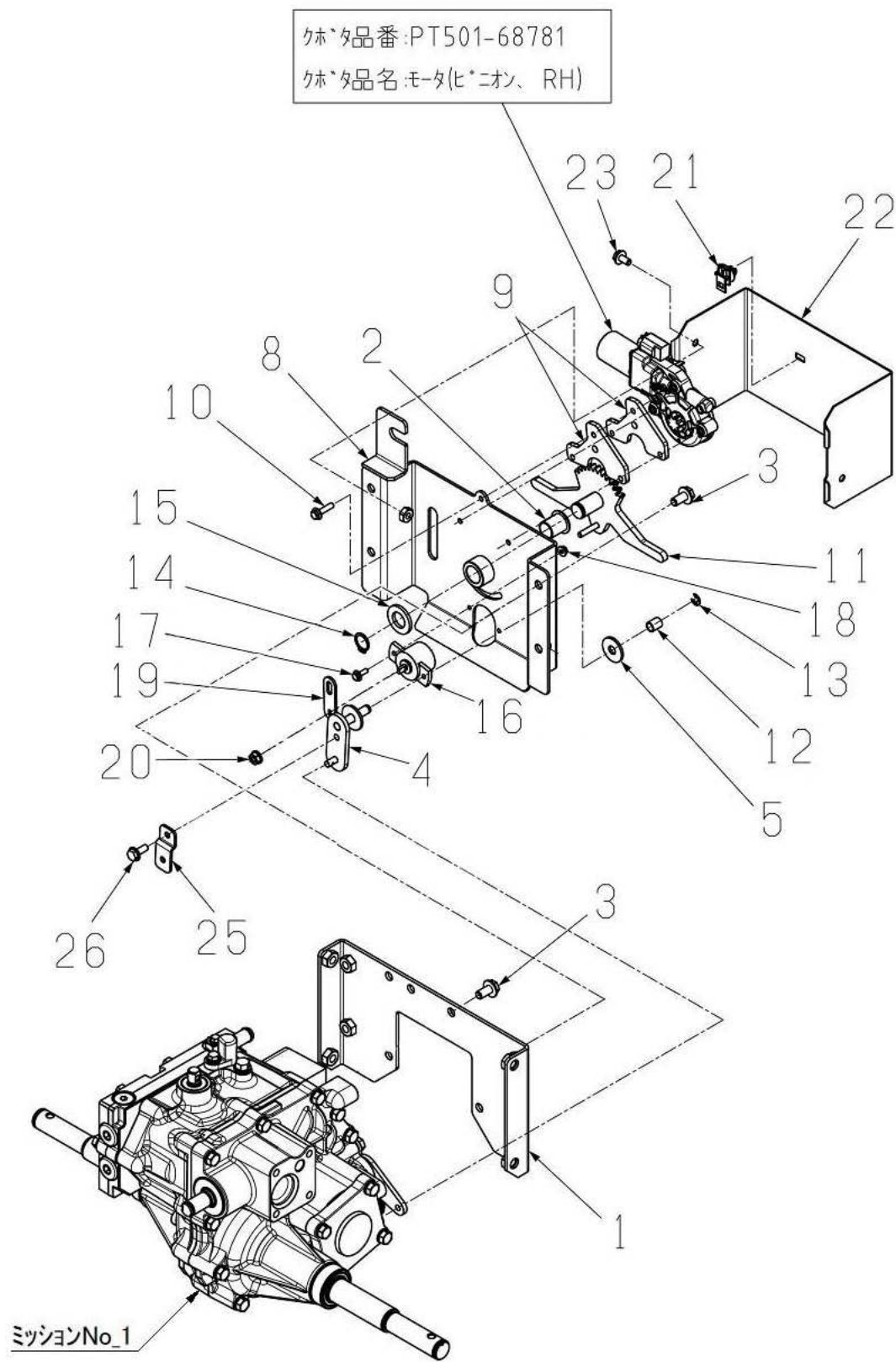

No	Product Number	Product Name	ST	Qty	Rev. Date	No
1	12100-BA2-800	BASE COMP, MISSION	B2	1		1101
2	91644-162080	BUSH, 80F-1620		1		1102
3	93100-0801617	BOLT, FLANGE 8 × 16		9		1103
4	12400-BA2-802	ARM COMP, BRAKE	B2	2		1105
5	91251-0835231	WASHER, RD 8 × 35 × 2.3	M1	2		1106
6	-					1107
7	-					1108
8	12300-BA2-802	BRACKET COMP, MOTER	B2	1		1109
9	33909-B96-802	SPACER B	B2	2		1112
10	91274-0502011	BOLT, UPSET 5 × 20		3		1113
11	12600-BA2-800	GEAR COMP	B2M	1		1115
12	12901-BA2-000	COLLAR, 8.2 × 10 × 12		2		1116
13	94511-06080	RING, E 6		2		1117
14	94510-16080	CIRCLIP, EX 16		1		1118
15	94101-16010	WASHER, PLAIN 16		1		1119
16	83100-B89-001	SENSOR, ANGLE RPA211		1		1121
17	83902-B89-000	BOLT, FRANGE SL M4 × 12		2		1123
18	94002-04410	NUT, FLANGE 4		2		1124
19	89301-BA2-800	STAY, SIDE CLUTCH	B2	1		1125
20	94002-06410	NUT, FLANGE 6		1		1126
21	81901-BA2-000	CLIP, COUPLER		1		1127
22	18901-BA2-801	COVER, SIDE CLUTCH	B2	1		1130
23	93100-0601217	BOLT, FLANGE 6 × 12		2		1132
25	12902-BA2-801	PLATE, STOPPER	B2	2		1141
26	93100-0601617	BOLT, FLANGE 6 × 16		2		1142

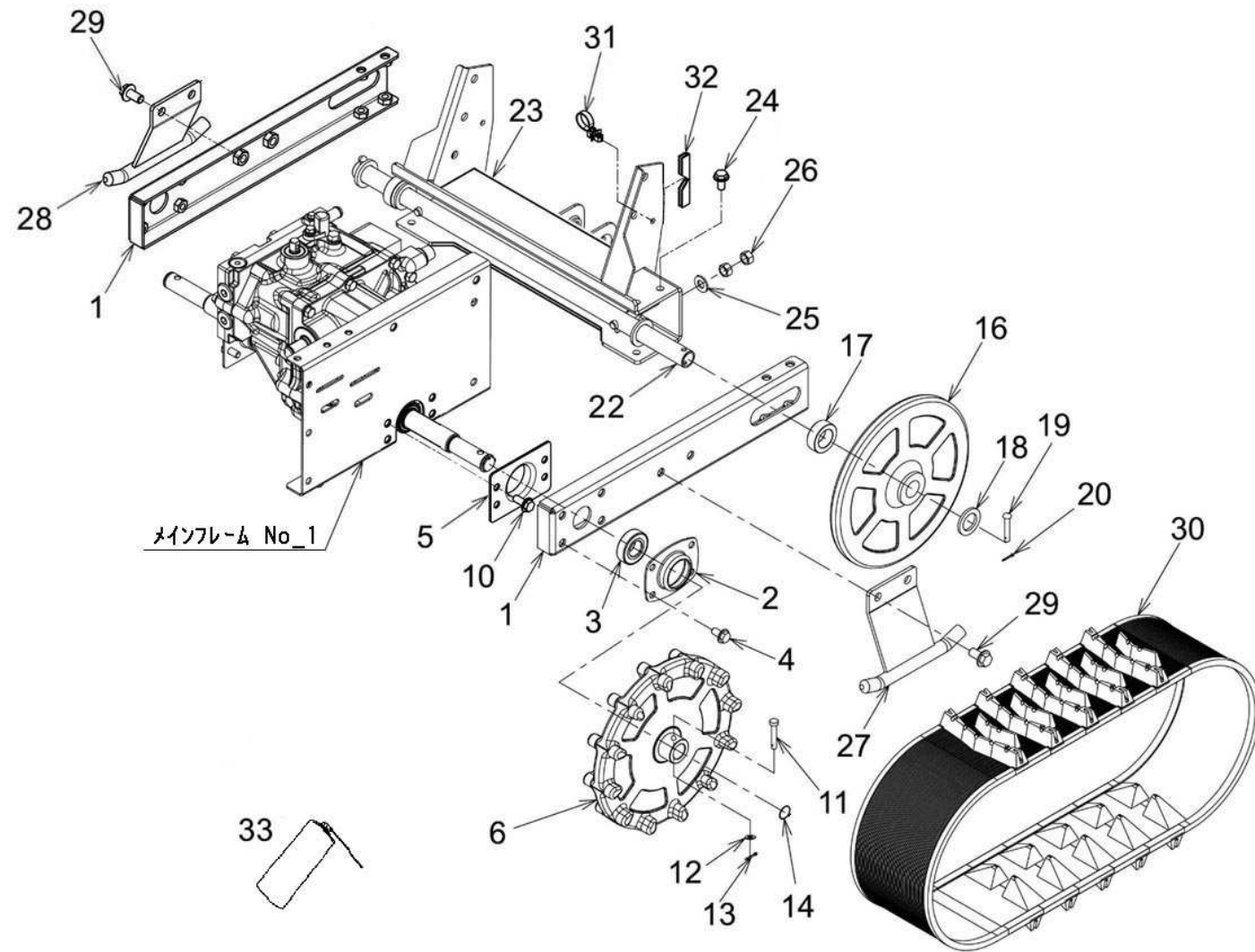

No	Product Number	Product Name	ST	Qty	Rev. Date	No
-	-	-				2008
1	21100-B96-803	FRAME COMP, CRAWLER	B2	2		2001
2	22902-B96-000	CASE, BEARING 6004	M1	2		2002
3	96105-06004	BEARING, 6004UU		2		2003
4	93100-0801617	BOLT, FLANGE 8 × 16		8		2004
5	21901-B96-800	GUIDE, TRANSMISSION	B2	2		2006
6	22600-B96-002	SPROCKET COMP, CRAWLER		2		2009
10	93100-0801617	BOLT, FLANGE 8 × 16		8		2007
11	26901-B96-002	PIN, DRIVE		2		2014
12	94101-06010	WASHER, PLAIN 6		2		2015
13	94210-20120	PIN, SPLIT 2 × 12		2		2016
14	94510-20080	CIRCLIP, EX 20		2		2017
16	22901-B96-001	WHEEL, DRIVEN		2		2019
17	22905-B96-800	COLLAR, 24 × 13	B2	2		2020
18	91251-2235321	WASHER, RD 22 × 35 × 3.2	M1	2		2021
19	94330-0603510	PIN, 6 × 35		2		2022
20	94210-20120	PIN, SPLIT 2 × 12		2		2023
22	21400-B96-830	SHAFT COMP, REAR	B2	1		2025
23	23500-B96-803	FRAME W COMP, REAR	B2	1		2026
24	93100-0801617	BOLT, FLANGE 8 × 16		8		2027
25	94101-10010	WASHER, PLAIN 10		2		2028
26	94005-10412	NUT, SMALL 10 × 1.25		4		2029
27	22100-B96-800	GUIDE L COMP, CRAWLER	B2	1		2031
28	22200-B96-800	GUIDE R COMP, CRAWLER	B2	1		2034
29	93300-1002017	BOLT, FLANGE 10 × 1.25 × 20		4		2032
30	L6161-26151	CRAWLER(130-59 × 23)		2		2033
31	-	-				2036
32	71901-BA2-000	PROTECTOR, RUBBER 12 × 70		1		2037
33	91972-03	SILICONE SPRAY, CRC		3		2038

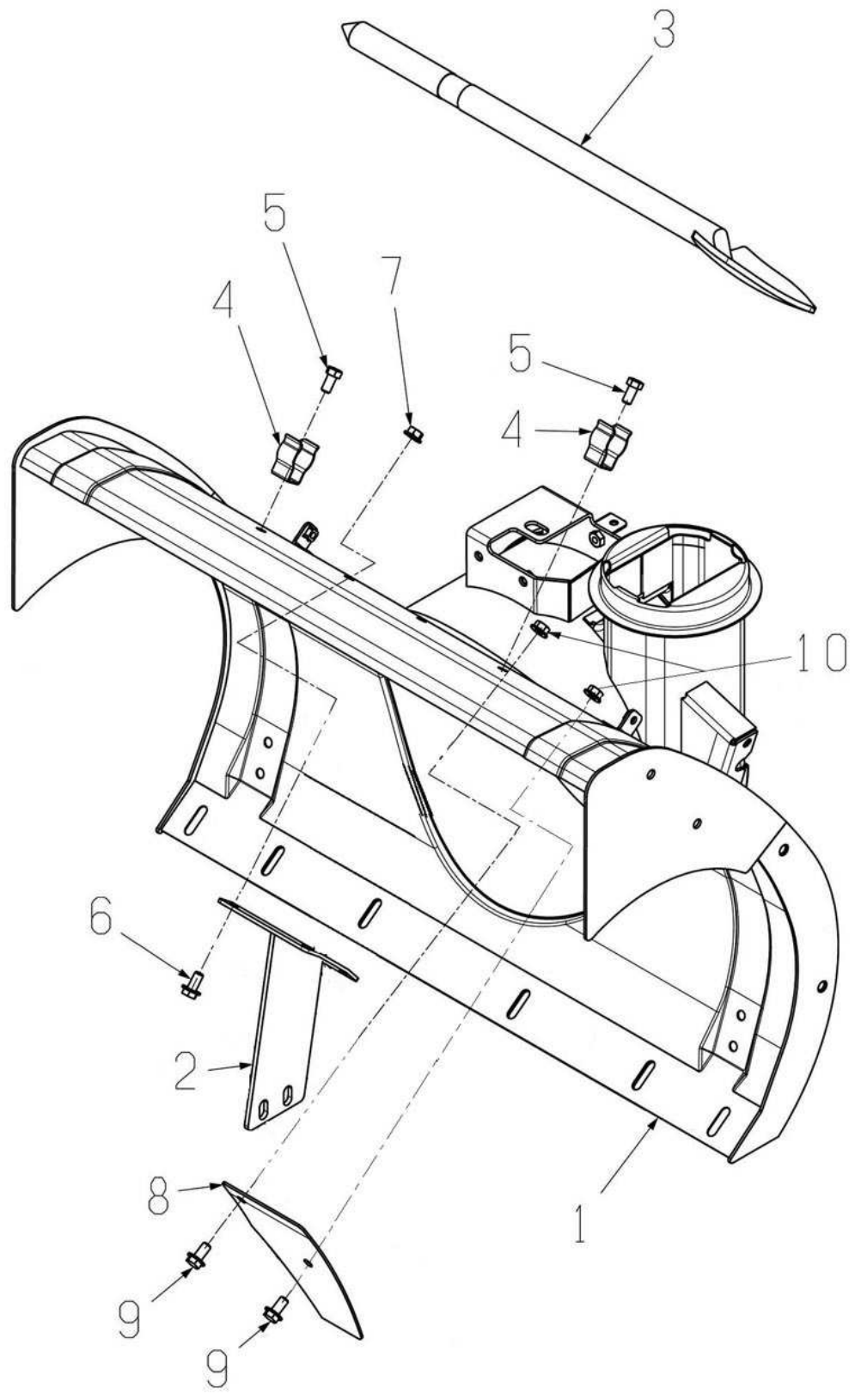

No	Product Number	Product Name	ST	Qty	Rev. Date	No
1	32600-B96-002	HOUSING COMP, AUGER	R6	1	Δ 2 2025/03/27	3001
2	31200-B96-801	SUPPORT COMP, GEAR CASE	B2	1	Δ 1 2025/04/21	3002
3	39901-B51-001	BAR, SNOW CLEANING		1		3003
4	39902-A65-001	HOLDER, BAR		2		3004
5	92200-0801617	BOLT, 8 × 16		2		3006
6	93100-0801617	BOLT, FLANGE 8 × 16		4		3007
7	94002-08410	NUT, FLANGE 8		6		3008
8	31909-B96-801	PLATE	B2	1		3210
9	93100-0801617	BOLT, FLANGE 8 × 16		2		3211
10	94002-08410	NUT, FLANGE 8		2		3212

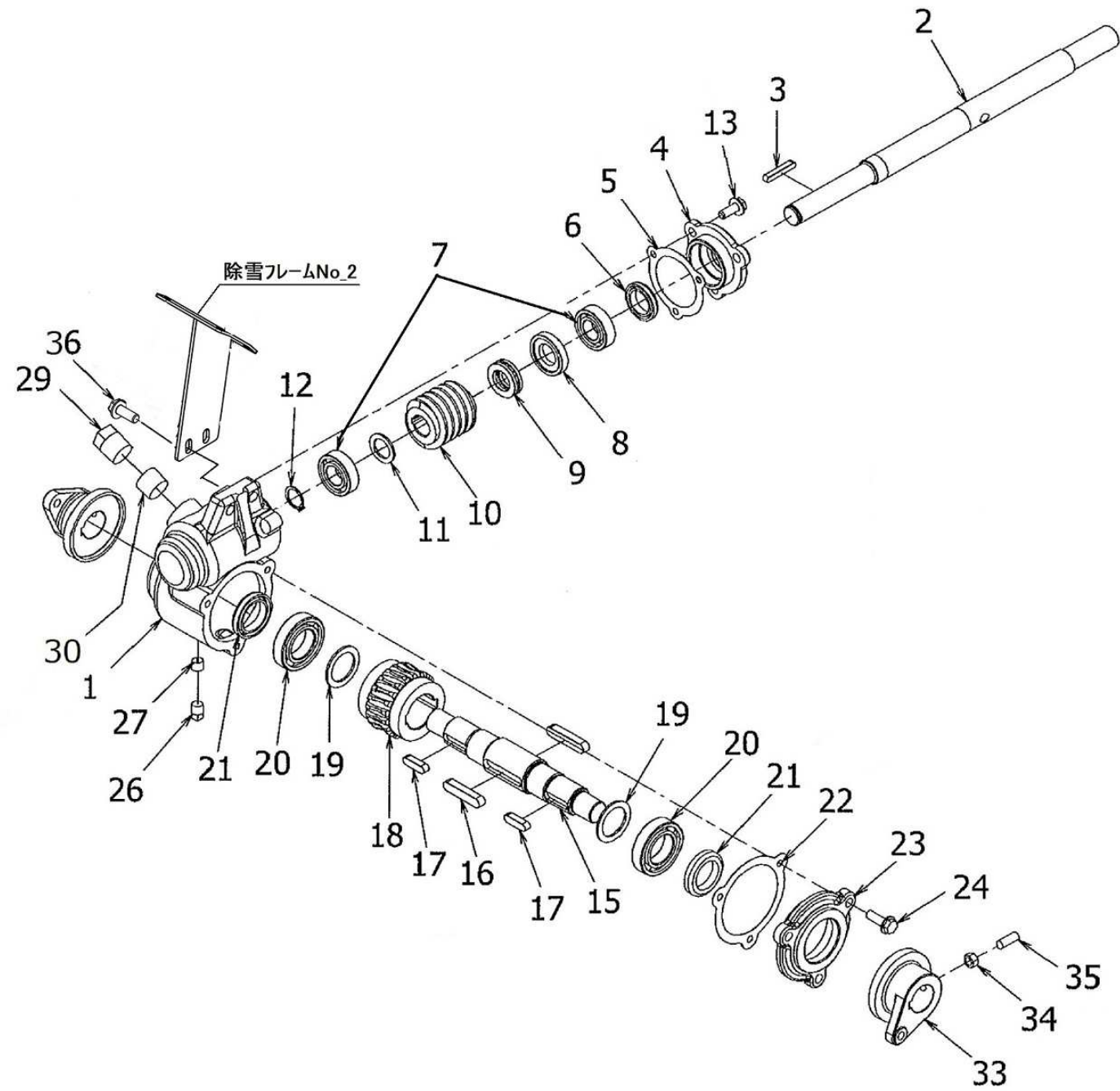

No	Product Number	Product Name	ST	Qty	Rev. Date	No
1	34901-B01-700	CASE, AUGER GEAR	B3M	1		3015
2	34901-B96-700	SHAFT, BLOWER	B3M	1		3027
3	97113-038241	KEY, 6×6×38RR		1		3033
4	31904-A31-701	COVER A, AUGER GEAR CASE	B3M	1		3013
5	39901-A31-002	PACKING A, AUGER GEAR CASE		1		3017
6	98251-2503807	SEAL, OIL D25387		1		3035
7	96100-06004	BEARING, 6004		2		3029
8	32904-A31-001	COLLAR, THRUST		1		3034
9	96200-051104	BEARING, THRUST 51104		1		3032
10	73251-V15-F002	GEAR, DRIVE		1		3031
11	91912-A05-001	WASHER, RD 20×30×2	M1	1		3030
12	94510-20080	CIRCLIP, EX 20		1		3028
13	93100-0802017	BOLT, FLANGE 8×20		3		3036
15	34902-B96-000	SHAFT, AUGER		1		3019
16	97116-048241	KEY, 10×8×48RR		2		3020
17	97115-028241	KEY, 8×7×28RR		2		3072
18	32902-A90-000	WORM WHEEL, M3×20		1		3021
19	91302-A31-000	WASHER, RD 30×42×2	M1	2		3022
20	96100-06006	BEARING, 6006		2		3023
21	98251-3004508	SEAL, OIL D30458		2		3024
22	39902-A31-002	PACKING B, AUGER GEAR CASE		1		3018
23	31905-A31-700	COVER B, AUGER GEAR CASE	B3M	1		3014
24	93100-0802517	BOLT, FLANGE 8×25		3		3025
26	91555-0141	PLUG, PT1/8		1		3037
27	91941-050	TAPE, SEAL 50		1		3038
29	91555-0641	PLUG, PT3/4		1		3039
30	91941-150	TAPE, SEAL 150		1		3040
33	35901-B96-800	SHEAR FLANGE ,AUGER	B2	2		3026
34	94003-08412	NUT, SMALL 8		2		3074
35	91221-082540	BOLT, HEX SOCKET 8×25		2		3073
36	93300-1002517	BOLT, FLANGE 10×1.25×25		2		3016

No	Product Number	Product Name	ST	Qty	Rev. Date	No
1	32903-B96-800	EDGE	B2	1		3201
2	92600-0801614	BOLT, CUP SQUARE NECK 8 × 16		6		3202
3	94101-08015	WASHER, PLAIN 8		6		3203
4	94002-08410	NUT, FLANGE 8		6		3204
5	31906-B96-800	SKID	B2	2		3206
6	31300-B96-800	BOLT COMP, SKID	B2	2		3207
7	94002-08410	NUT, FLANGE 8		4		3208
8	65901-BA2-000	COVER, BELT		1		3214
9	48905-B96-000	BOLT, SHOULDER 6 × 9	M0	2		3215
10	91315-C1J77	CLIP, CABLE C-1J77		2		3216

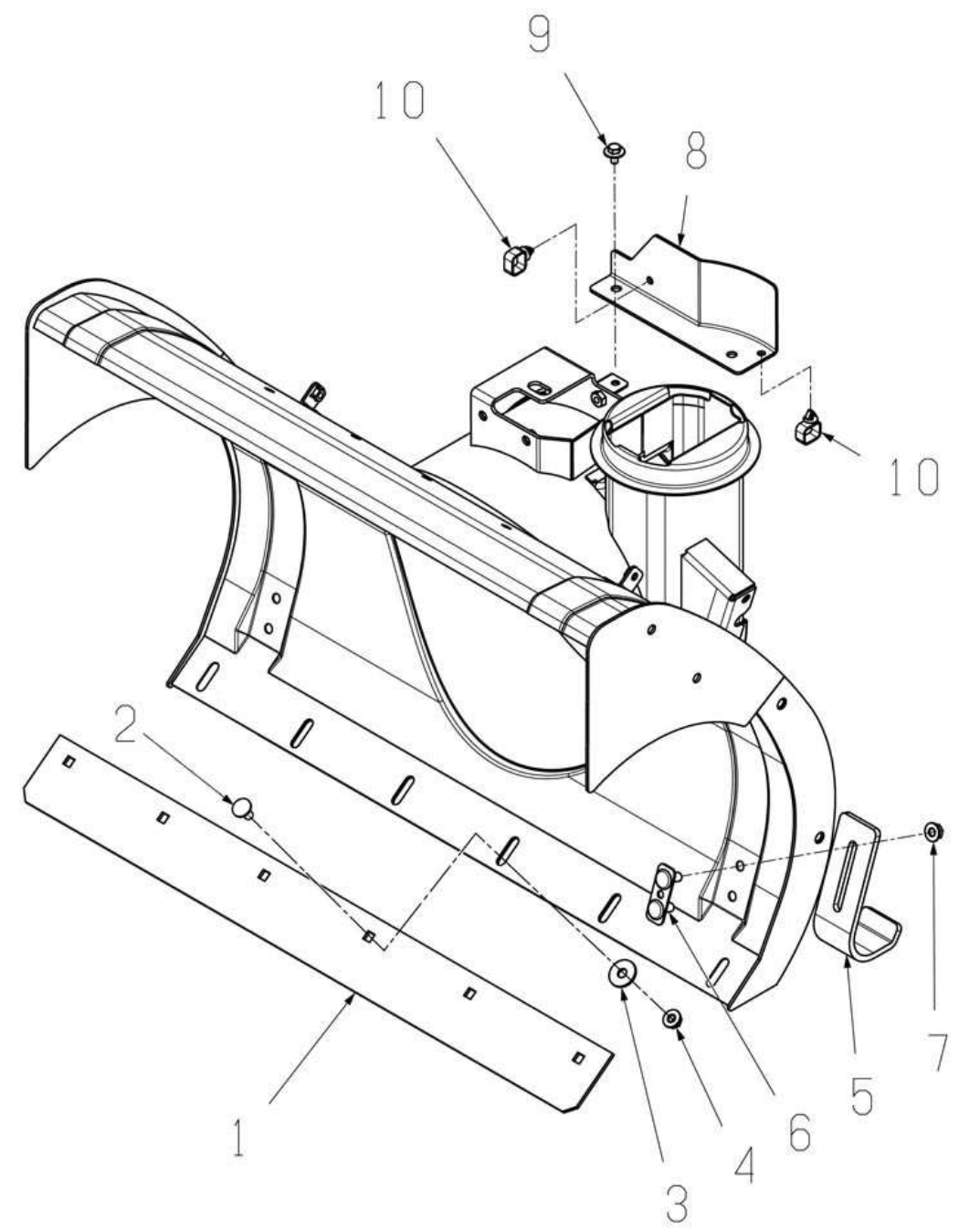

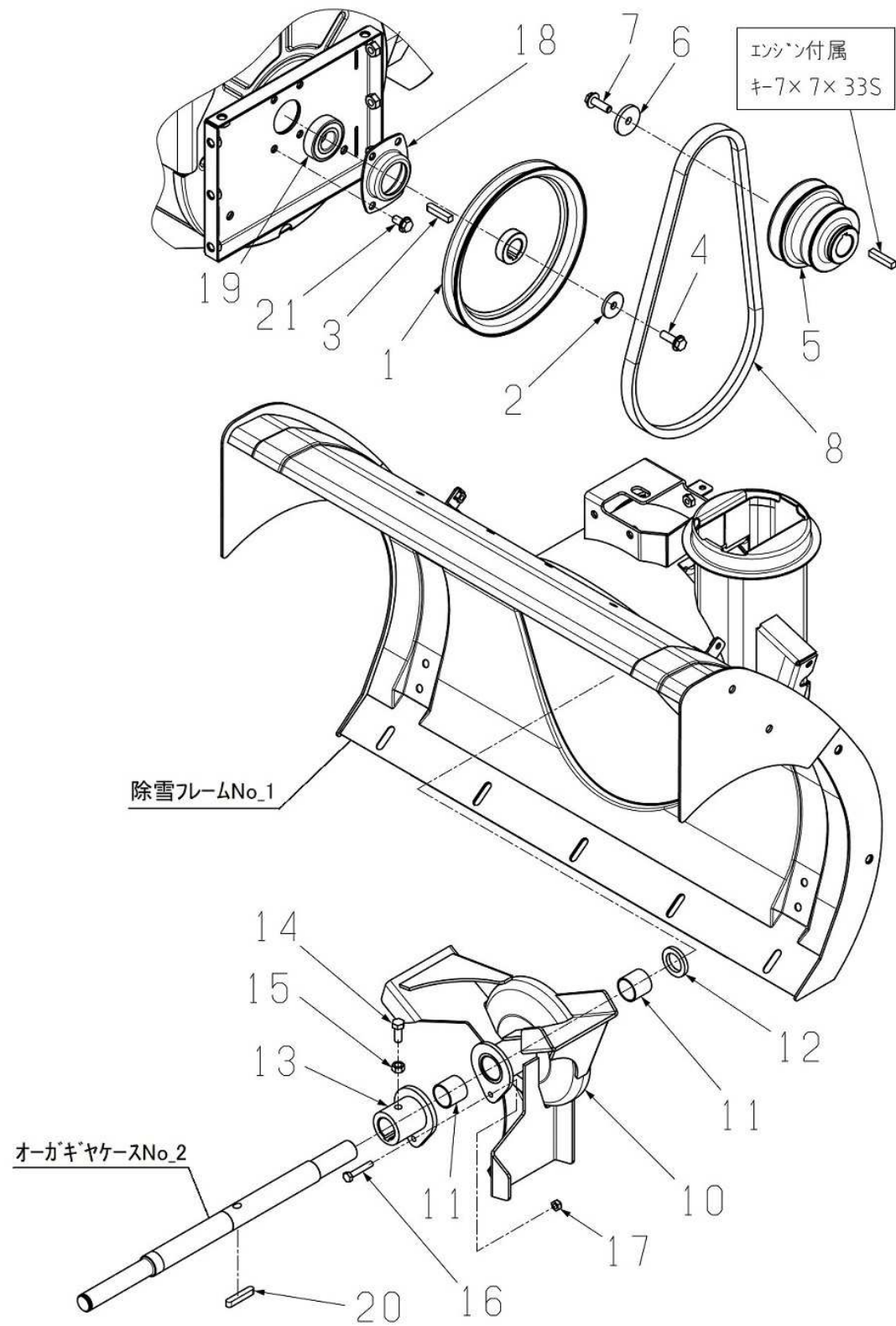

No	Product Number	Product Name	ST	Qty	Rev. Date	No
1	64100-B96-001	PULLEY COMP, 215.9B	M1	1		3051
2	91251-0835321	WASHER, RD 8×35×3.2	M1	1		3052
3	97114-035141	KEY, 7×7×35SR		1		3053
4	93100-0802517	BOLT, FLANGE 8×25		1		3054
5	64902-B96-701	PULLEY, ENGINE	B3M	1		3056
6	91251-0835451	WASHER, RD 8×35×4.5	M1	1		3057
7	93100-0802517	BOLT, FLANGE 8×25		1		3058
8	64903-B96-000	BELT W1000, SB38		1		3060
10	36100-B96-801	BLOWER COMP	B2	1		3101
11	91646-2525R	BUSH, BM2525FS		2		3102
12	91251-2235451	WASHER, RD 22×35×4.5	M1	1		3103
13	36300-B96-802	FLANGE COMP, BLOWER SHEAR	B2	1		3104
14	91212-0820147	BOLT, POINTED 8×20		1		3105
15	94003-08412	NUT, SMALL 8		1		3106
16	92000-0602517	BOLT, 6×25		1		3107
17	91234-064110	NUT, TOUGH LOCK 6		1		3108
18	25901-B01-000	CASE B, BEARING	M1	1		3109
19	96105-06222	BEARING, 62/22UU		1		3110
20	97114-040241	KEY, 7×7×40RR		1		3111
21	93100-0801617	BOLT, FLANGE 8×16		4		3112

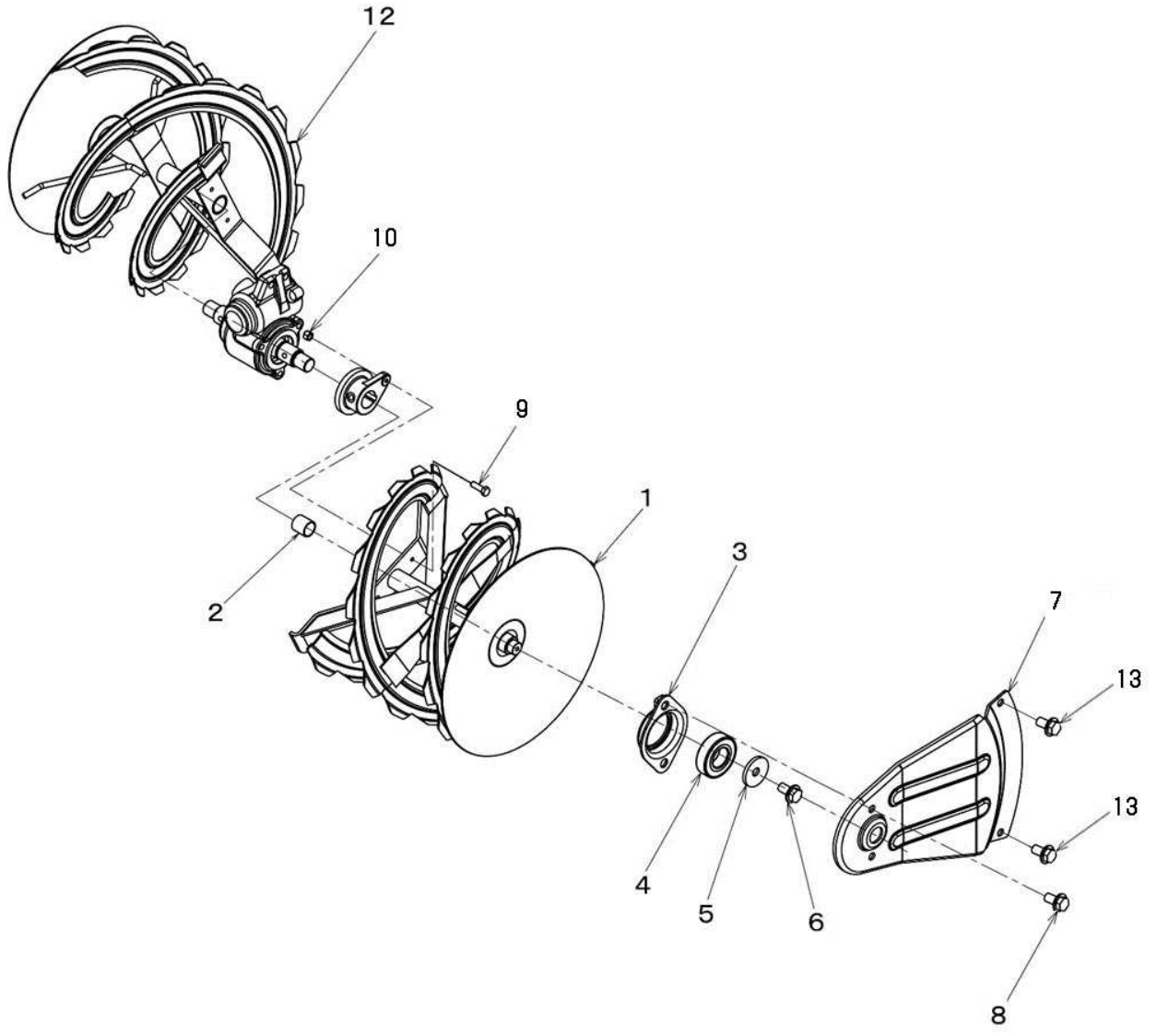

No	Product Number	Product Name	ST	Qty	Rev. Date	No
1	35300-B96-603	AUGER L COMP	B4M	1		3043
2	91646-2225R	BUSH, BM2225FS		2		3045
3	35400-B01-001	CASE A COMP, BEARING	M1	2		3047
4	96105-06004	BEARING, 6004UU		2		3046
5	91251-0830321	WASHER, RD 8 × 30 × 3.2	M1	2		3048
6	93100-0801617	BOLT, FLANGE 8 × 16		2		3071
7	31902-B96-000	SUPPORT, AUGER SIDE	R6	2		3049
8	93100-0801617	BOLT, FLANGE 8 × 16		4		3050
9	92000-0602517	BOLT, 6 × 25		2		3077
10	91234-064110	NUT, TOUGH LOCK 6		2		3078
12	35400-B96-603	AUGER R COMP	B4M	1		3044
13	93100-0801617	BOLT, FLANGE 8 × 16		4		3218

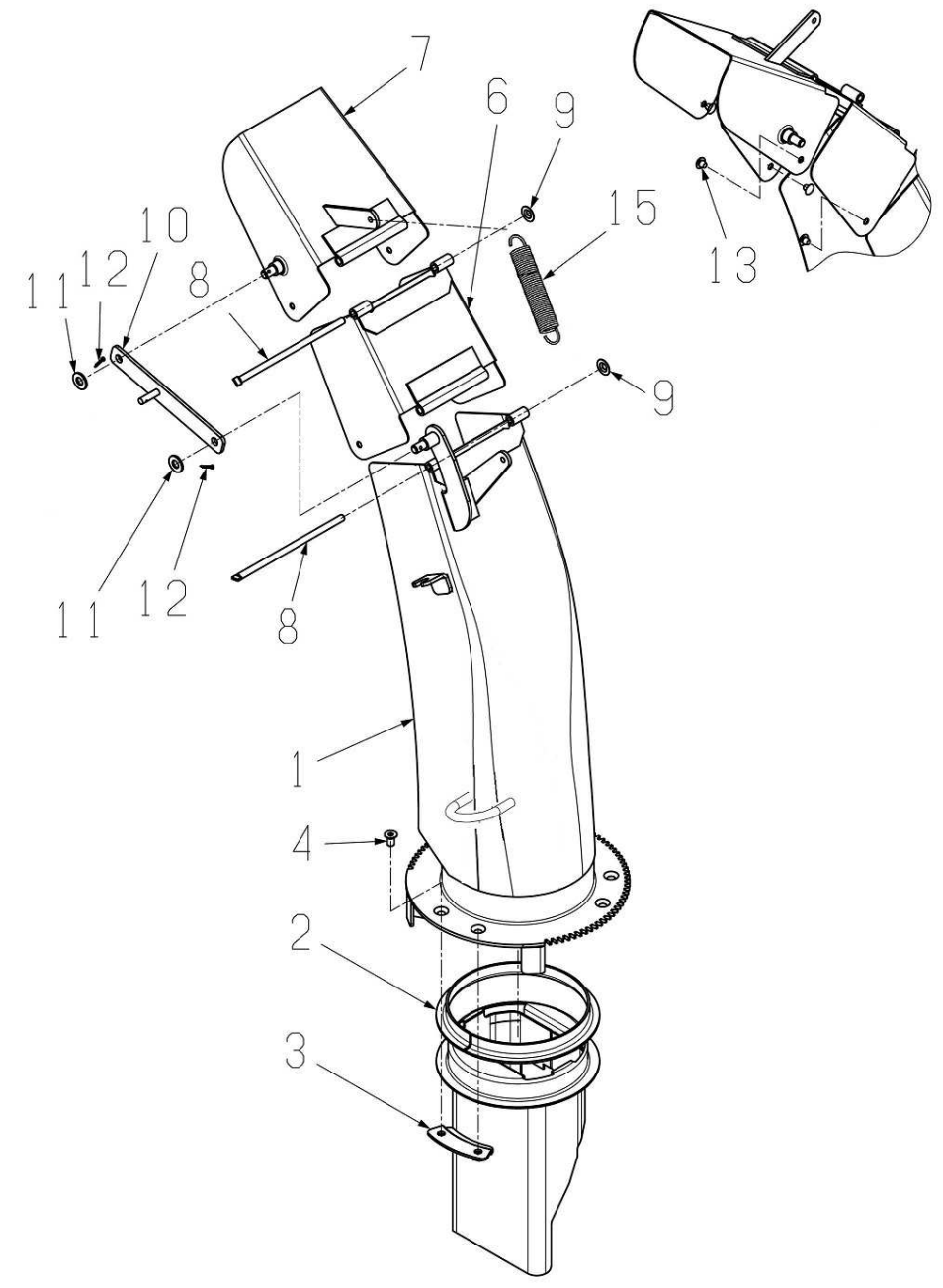

No	Product Number	Product Name	ST	Qty	Rev. Date	No
	-					3305
1	33100-B96-004	CHUTE COMP	R6	1		3301
2	33903-B96-002	SHEET, CHUTE		1		3302
3	33600-B96-001	CLAMP COMP, CHUTE	M1	3		3303
4	91217-0601274	BOLT, COUNTERSUNK HEX SOCKET 6 × 12		6		3304
6	33200-B96-803	DEFLECTOR A COMP, CHUTE	B2	1		3306
7	33300-B96-803	DEFLECTOR B COMP, CHUTE	B2	1		3307
8	33906-B96-000	PIN, CHUTE	M1	2		3308
9	91243-06000	NUT, PUSH 6		2		3309
10	37200-B96-830	LINK COMP, CHUTE	B2	1		3310
11	94101-08010	WASHER, PLAIN 8		2		3311
12	94210-20120	PIN, SPLIT 2 × 12		2		3312
13	91361-0403	PLUG, HOLE 0403		4		3313
15	33904-B01-104	SPRING, COIL 19.7 × 127	M0B	1		3315

No	Product Number	Product Name	ST	Qty	Rev. Date	No
1	31901-B96-801	BRACKET COMP,MOTOR	B2	1		3320
2	91274-0501612	BOLT, UPSET 5×16		3		3321
3	93100-0601217	BOLT, FLANGE 6×12		4		3322

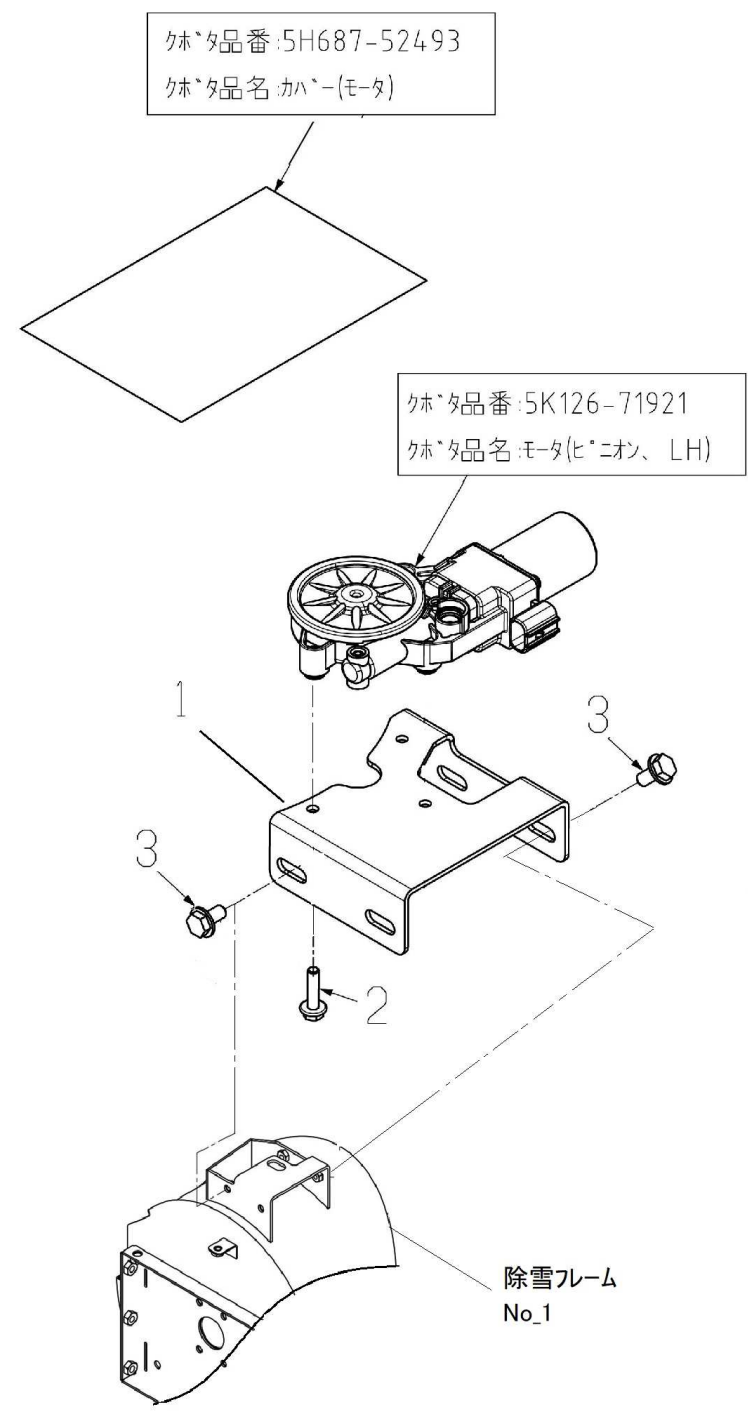

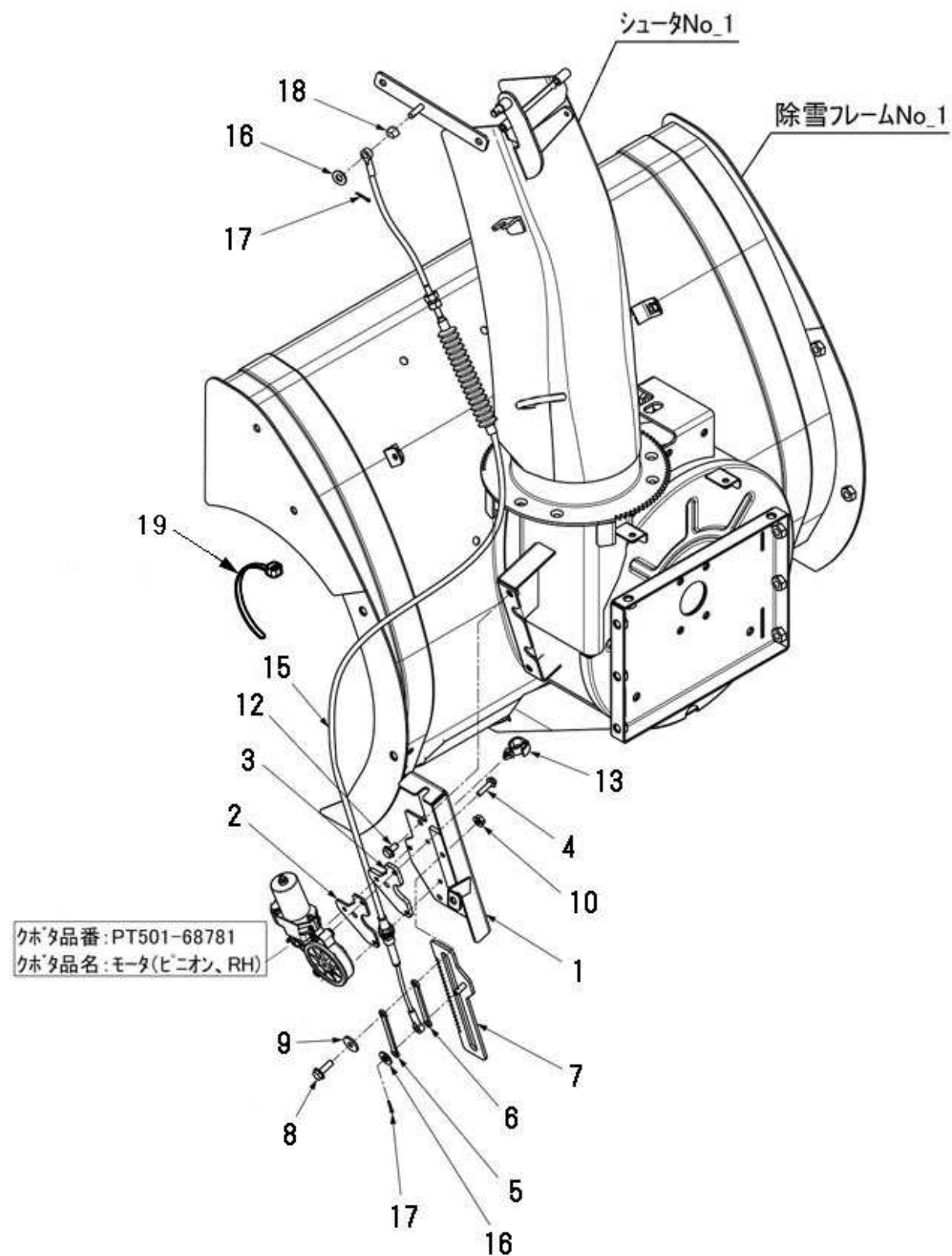

No	Product Number	Product Name	ST	Qty	Rev. Date	No
1	33400-B96-831	BRACKET A COMP, MOTOR	B2	1		3325
2	33909-B96-802	SPACER B	B2	1		3327
3	33908-B96-802	SPACER A	B2	1		3326
4	91274-0501612	BOLT, UPSET 5×16		3		3328
5	31907-B96-801	PLATE A, STOPPER	B2	1		3329
6	31908-B96-802	PLATE B, STOPPER	B2	1		3330
7	33500-B96-830	RACK COMP, CHUTE	B2	1		3331
8	93100-0602017	BOLT, FLANGE 6×20		2		3332
9	94101-06015	WASHER, PLAIN 6		2		3333
10	94002-06410	NUT, FLANGE 6		2		3334
11	-					3335
12	93100-0601617	BOLT, FLANGE 6×16		2		3336
13	91315-C4397	CLIP, CABLE C-4397		1		3337
15	77400-B96-000	WIRE, CHUTE		1		3338
16	94101-06010	WASHER, PLAIN 6		2		3339
17	94210-20120	PIN, SPLIT 2×12		2		3340
18	96901-BA1-000	COLLAR 6×4.5		1		3314
19	91310-150	BAND, PRT1.5S		1		3342

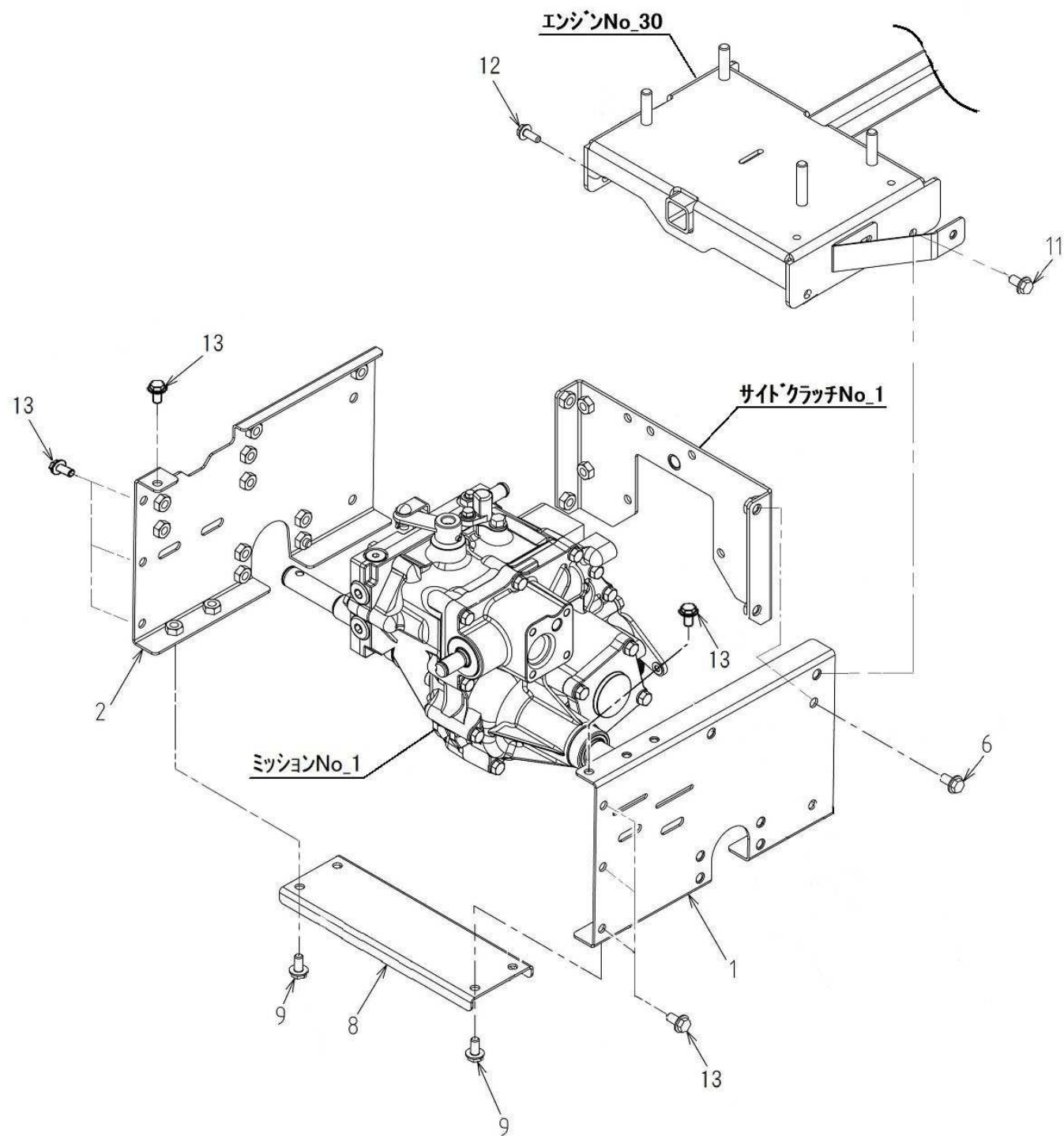

No	Product Number	Product Name	ST	Qty	Rev. Date	No
1	41100-B96-830	FRAME L COMP, MAIN	B2	1		4001
2	41200-B96-830	FRAME R COMP, MAIN	B2	1		4004
6	93100-0801617	BOLT, FLANGE 8 × 16		4		1114
8	41901-B96-800	PLATE, UNDER	B2	1		4011
9	93100-0801617	BOLT, FLANGE 8 × 16		4		4012
11	93100-0802017	BOLT, FLANGE 8 × 20		2		4002
12	93100-0802017	BOLT, FLANGE 8 × 20		2		4005
13	93100-0801617	BOLT, FLANGE 8 × 16		8		4014

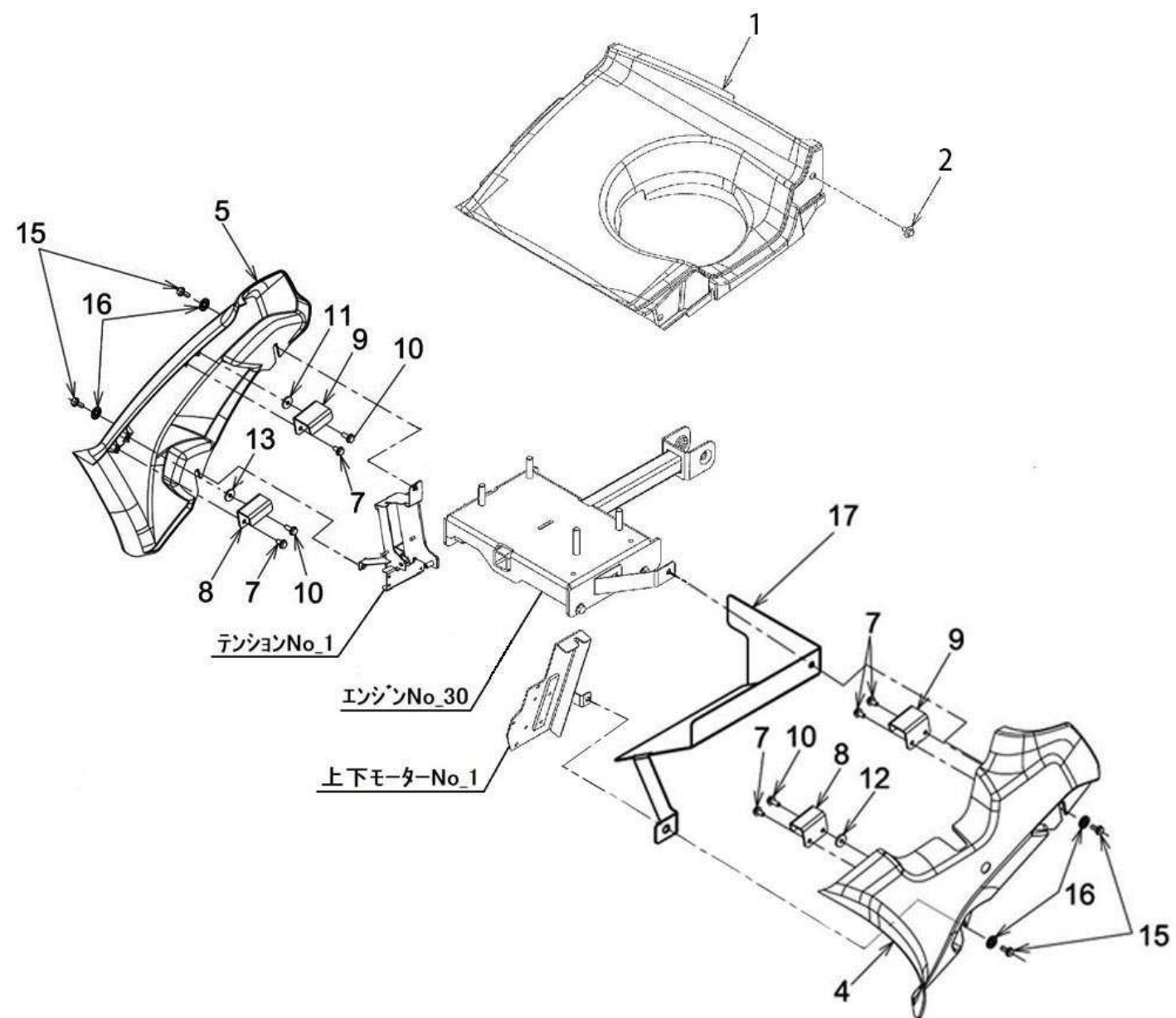

No	Product Number	Product Name	ST	Qty	Rev. Date	No
1	48903-B96-031	COVER CH, BODY		1		4106
2	48905-B96-000	BOLT, SHOULDER 6×9	M0	4		4107
4	48500-B96-004	COVER L, BODY		1	Δ 1 2026/01/29	4101
5	48600-B96-003	COVER R, BODY		1	Δ 1 2026/01/29	4102
7	93100-0601217	BOLT, FLANGE 6×12		5		4105
8	48904-B96-801	FRONT HOOK, COVER	B2	2		4103
9	48906-B96-801	REAR HOOK, COVER	B2	2		4104
10	93100-0601617	BOLT, FLANGE 6×16		3		4110
11	94101-06015	WASHER, PLAIN 6		1		4109
12	91251-0620321	WASHER, RD6×20×3.2	M1	1		4111
13	48914-B96-000	WASHER, RD6×20×6	M1	1		4113
15	93100-0601617	BOLT, FLANGE 6×16		4		4114
16	94101-06015	WASHER, PLAIN 6		4		4115
17	04700-B96-800	COVER COMP, SIDE	B2	1		4116

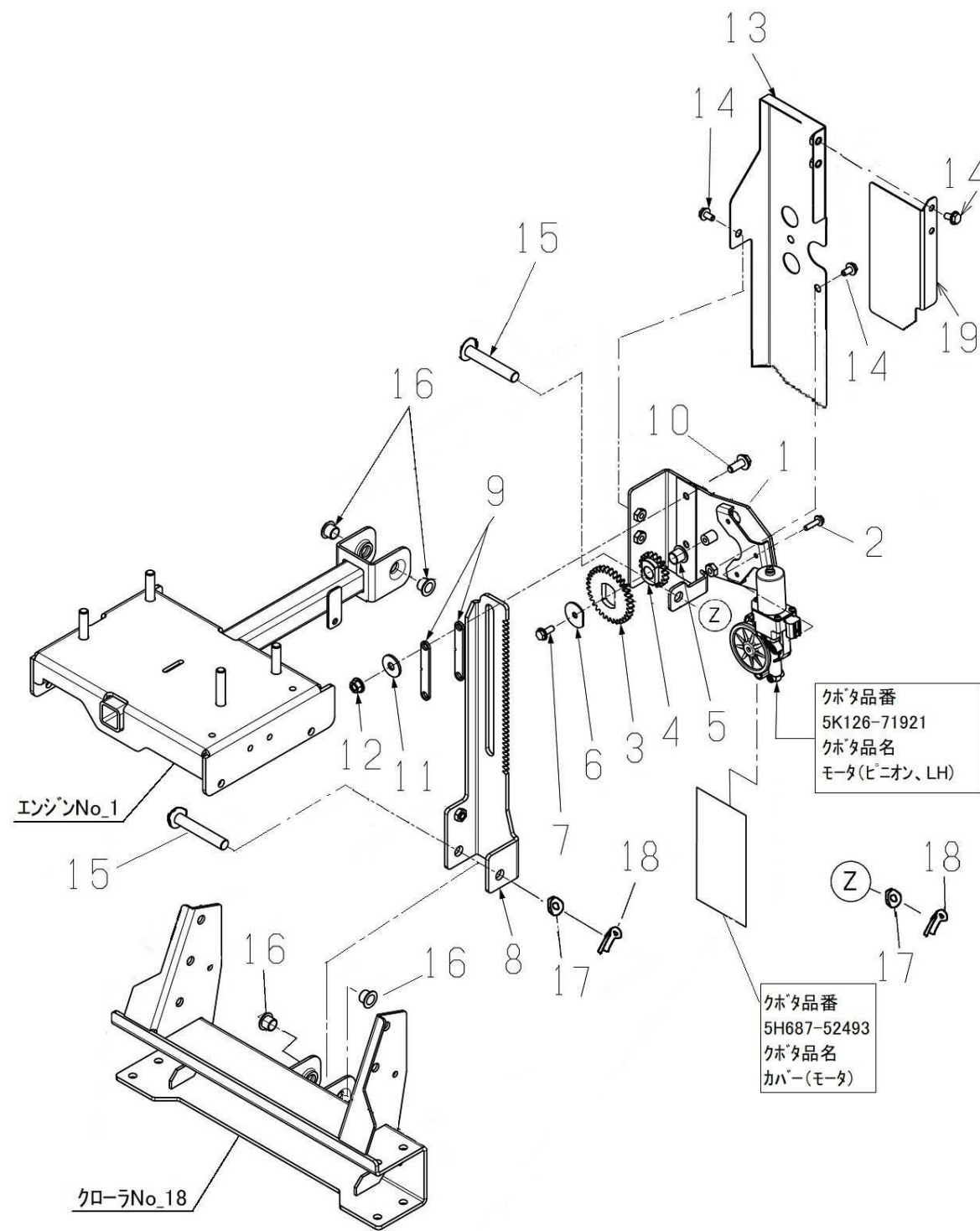

No	Product Number	Product Name	ST	Qty	Rev. Date	No
1	72200-B96-801	BRACKET B COMP, MOTOR	B2	1	Δ 1 2025/03/11	7102
2	91274-0501612	BOLT, UPSET 5 × 16		3		7103
3	33902-B56-002	GEAR, M2 × 32		1		7104
4	33903-B56-003	GEAR, M2 × 18		1		7105
5	91644-121080	BUSH, 80F-1210		1		7106
6	71903-B96-002	WASHER, D-SHAPED 6.5 × 30	M1	1		7107
7	93100-0601617	BOLT, FLANGE 6 × 16		1		7108
8	71400-B96-850	RACK COMP, HEIGHT	B2	1		7111
9	71904-B96-830	PLATE, STOPPER	B2	2		7112
10	71912-B96-000	BOLT, FLANGE PRECOATED 8 × 20		2	Δ 1 2025/09/16	7113
11	94101-08015	WASHER, PLAIN 8		2		7114
12	94002-08410	NUT, FLANGE 8		2		7115
15	94330-1208010	PIN, 12 × 80		2		7121
16	72300-B96-801	COVER A COMP, MOTOR	B2	1	Δ 1 2025/03/11	7117
16	91644-121080	BUSH, 80F-1210		4		7122
17	93100-0601217	BOLT, FLANGE 6 × 12		4		7118
17	94101-12010	WASHER, PLAIN 12		2		7123
18	94210-30250	PIN, SPLIT 3 × 25		2		7124
19	72903-B96-801	COVER B, MOTOR	B2	1	Δ 1 2025/03/11	7119

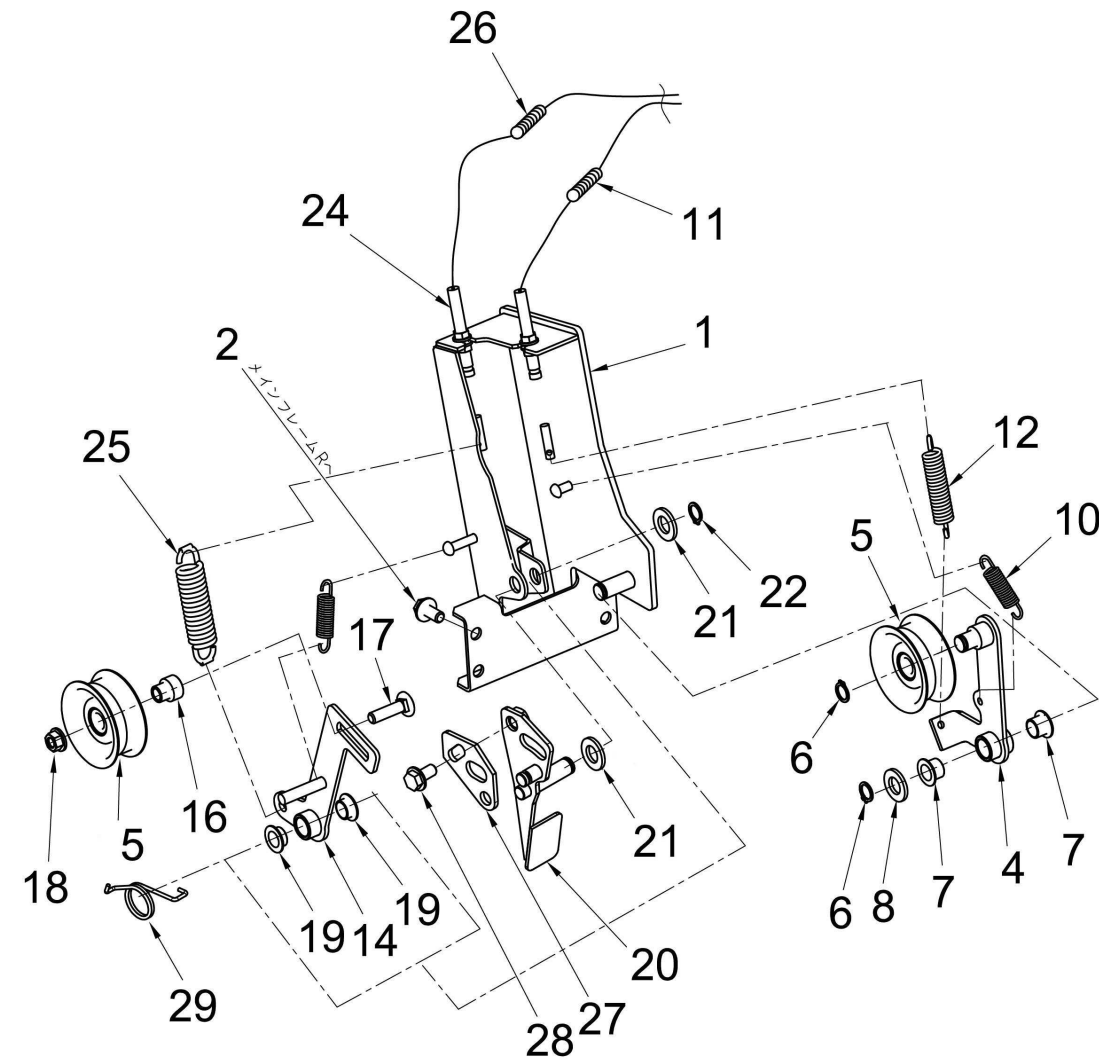

No	Product Number	Product Name	ST	Qty	Rev. Date	No
1	61400-B96-802	BRACKET COMP, TENSION ARM	B2M	1		6001
2	93100-0801617	BOLT, FLANGE 8 × 16		4		6002
4	68200-B96-800	ARM COMP, TRAVEL CLUTCH	B2M	1		6003
5	91615-12552243	PULLEY, TENSION 55TB1		2		6007
6	94510-12080	CIRCLIP, EX 12		2		6006
7	91644-121080	BUSH, 80F-1210		2		6004
8	91251-1220231	WASHER, RD 12 × 20 × 2.3	M1	1		6005
10	91603-B50-001	SPRING, COIL 10 × 50	M1B	2		6018
11	77700-BA1-000	WIRE, TRAVEL CLUTCH (E		1		6031
12	71906-B96-000	SPRING, TRAVEL TENSION	M1B	1		6032
14	66500-B96-800	ARM COMP, AUGER CLUTCH	B2	1		6009
16	66902-B96-002	COLLAR, TENSION	M1	1		6014
17	92600-0803514	BOLT, CUP SQUARE NECK 8 × 30		1		6015
18	94002-08410	NUT, FLANGE 8		1		6016
19	91642-1210R	BUSH, BM1210F20FS		2		6010
20	66600-B96-800	BRAKE COMP, BLOWER	B2M	1		6011
21	94101-12010	WASHER, PLAIN 12		2		6012
22	94510-12080	CIRCLIP, EX 12		1		6013
24	77800-BA1-000	WIRE, AUGER CLUTCH (E		1		6041
25	71907-B96-000	SPRING, AUGER TENSION	M1B	1		6042
26	91382-0703001	CORRUGATE 7 × 300		2		6033
27	66906-B96-800	ADJUSTER, BRAKE	B2	1		6061
28	93100-0801617	BOLT, FLANGE 8 × 16		1		6062
29	91601-B96-000	SPRING, RETURN 2.3		1		6063

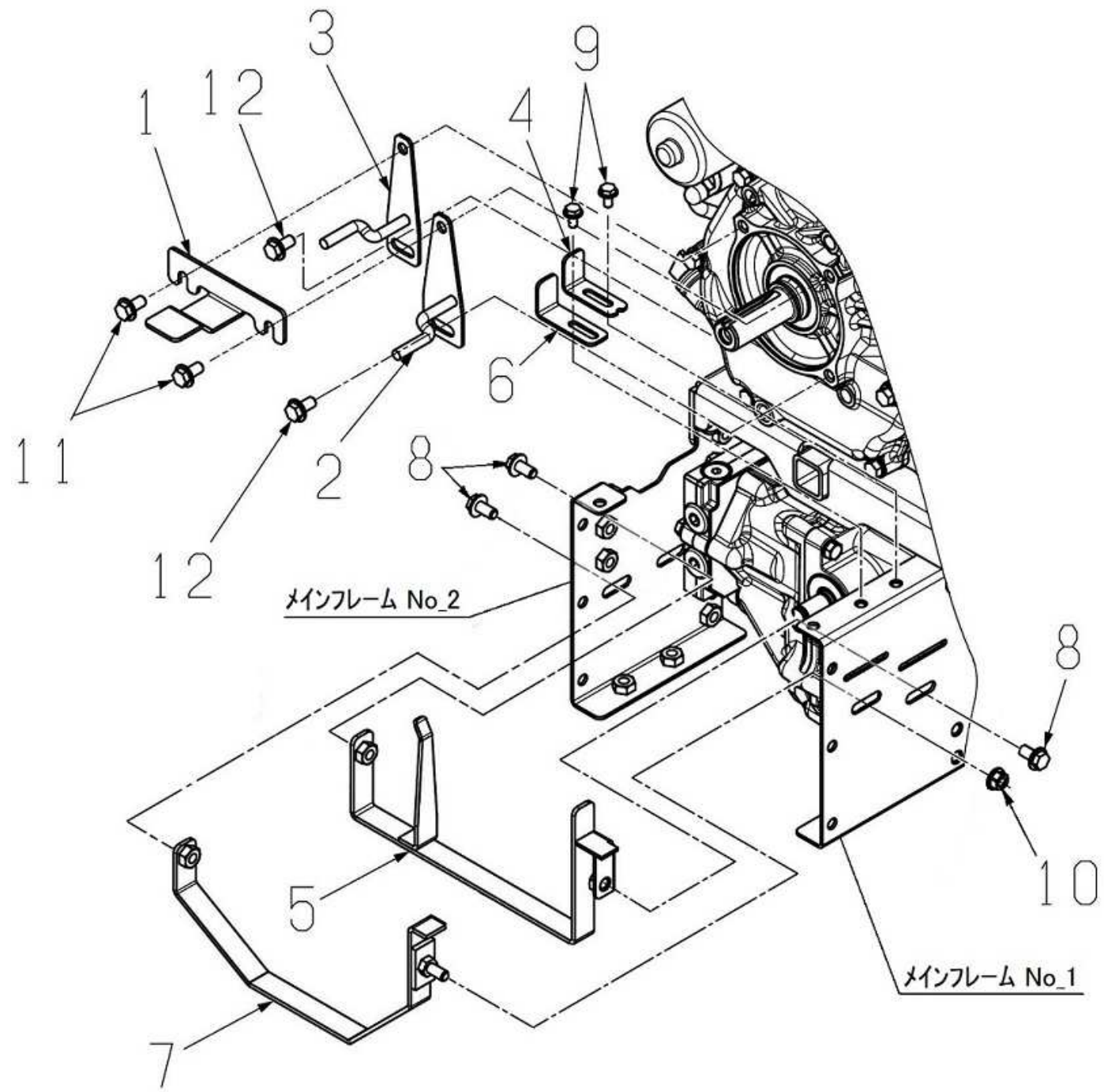

No	Product Number	Product Name	ST	Qty	Rev. Date	No
1	65905-B96-800	STOPPER F, BELT	B2	1		6019
2	63400-B96-830	STOPPER AL COMP, BELT	B2	1		6020
3	63700-B96-800	STOPPER AR COMP, BELT	B2	1		6021
4	65903-B96-803	STOPPER C, BELT	B2	1		6025
5	67100-B96-801	STOPPER B COMP, BELT	B2	1		6024
6	65904-B96-800	STOPPER E, BELT	B2	1		6029
7	67200-B96-801	STOPPER D COMP, BELT	B2	1		6026
8	93100-0801617	BOLT, FLANGE 8 x 16		3		6027
9	93100-0601217	BOLT, FLANGE 6 x 12		2		6028
10	94002-08410	NUT, FLANGE 8		1		6023
11	93100-0802017	BOLT, FLANGE 8 x 20		2		6030
12	93100-0801617	BOLT, FLANGE 8 x 16		2		6052

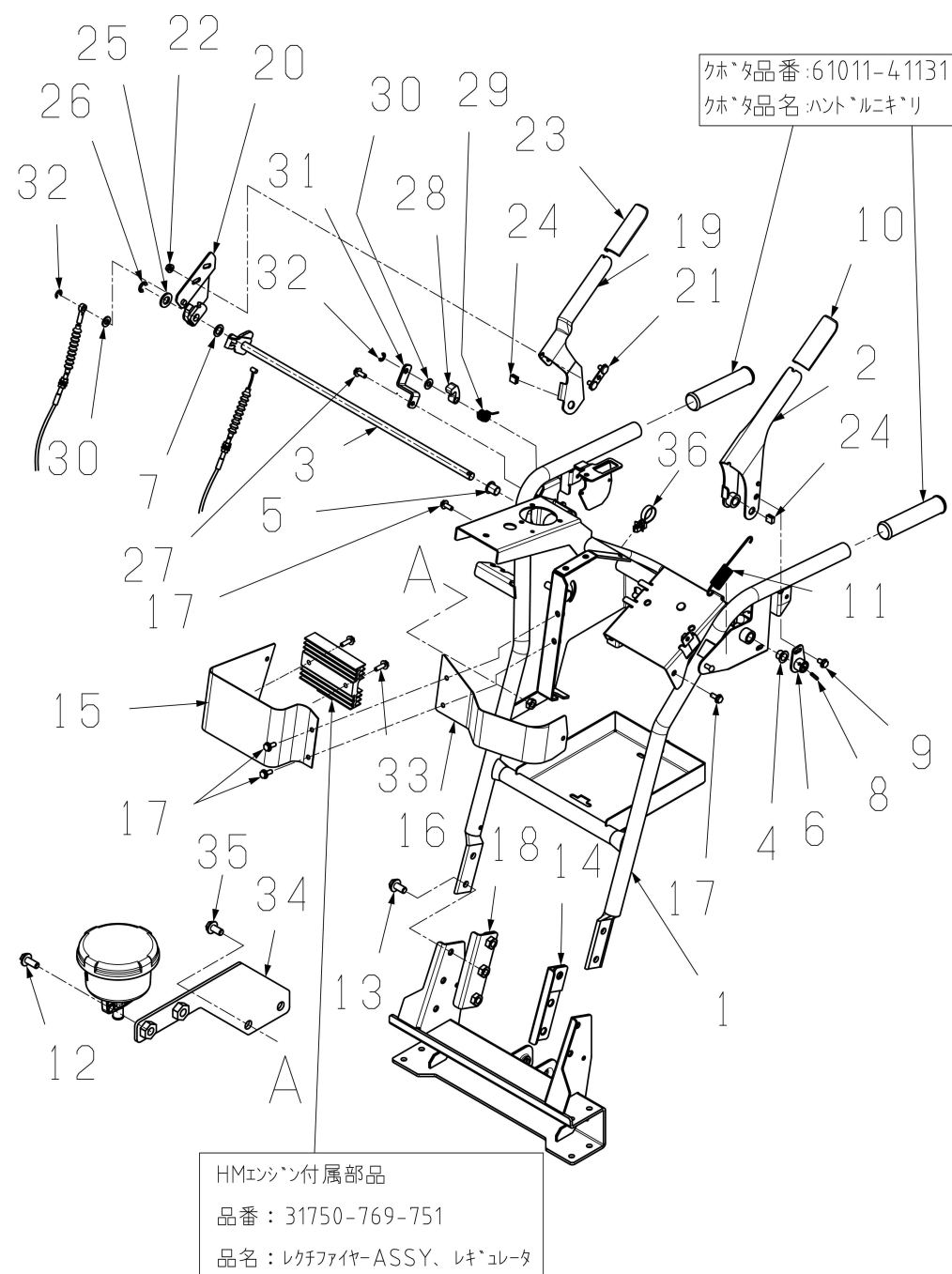

No	Product Number	Product Name	ST	Qty	Rev. Date	No
-	-					7010
1	71200-BA2-604	HANDLE COMP	B4M	1	Δ 1 2024/12/10	7001
2	73500-B96-634	LEVER COMP, TRAVEL CLUTCH	B4	1	Δ 1 2025/02/06	7002
3	76400-B96-806	SHAFT COMP	B2	1		7003
4	91644-121080	BUSH, 80F-1210		1		7004
5	91644-121580	BUSH, 80F-1215		1		7005
6	74100-B96-634	BOSS COMP, JOINT	B4	1	Δ 2 2025/02/06	7006
7	73903-B96-000	SHIM 12 × 20 × 1.2	M1	1		7007
8	94319-40020	PIN, SPG 4 × 20		1		7008
9	93100-0601217	BOLT, FLANGE 6 × 12		1		7009
10	73901-B96-001	COVER, DIPPING		1		7011
11	71905-B96-101	SPRING, CLUTCH LEVER	MOB	1		7012
12	93100-0802017	BOLT, FLANGE 8 × 20		2		7013
13	93300-1002017	BOLT, FLANGE 10 × 1.25 × 20		6		7014
14	72400-B96-800	LINK L COMP, HANDLE	B2	1		7015
15	78300-B96-803	COVER A COMP, FRONT	B2	1		7017
16	78908-B96-832	COVER B, FRONT	B2	1		7018
17	93100-0601257	BOLT, FLANGE 6 × 12		4		7019
18	72500-B96-800	LINK R COMP, HANDLE	B2	1		7016
19	73700-B96-800	LEVER COMP, AUGER CLUTCH	B2	1		7021
20	79904-B89-000	LABEL, WADO 78		1		7020
20	73400-B96-832	BRACKET COMP, AUGER CLUTCH	B2	1		7022
21	76500-B96-801	PLATE COMP, SET	B2	1		7023
22	94002-06410	NUT, FLANGE 6		2		7024
23	73901-B96-001	COVER, DIPPING		1		7025
24	71909-B96-000	PROTECTOR, RUBBER 12 × 10		2		7026
25	94101-12010	WASHER, PLAIN 12		1		7027
26	94511-09010	RING, E 9		1		7028
27	93100-0601617	BOLT, FLANGE 6 × 16		1		7029
28	73905-BA2-000	CAM		1		7030
29	71901-B96-001	SPRING	M1B	1		7031
30	94101-08010	WASHER, PLAIN 8		2		7032
31	78903-B96-801	STAY	B2	1		7033
32	94511-07010	RING, E 7		2		7034
33	93100-0602017	BOLT, FLANGE 6 × 20		2		7035
34	71800-B96-800	STAY COMP, SUB TANK	B2	1	Δ 1 2024/12/20	7037
35	93100-0801617	BOLT, FLANGE 8 × 16		2		7038
36	91314-119P7	STRAP, CABLE 1-19P7		1		7036

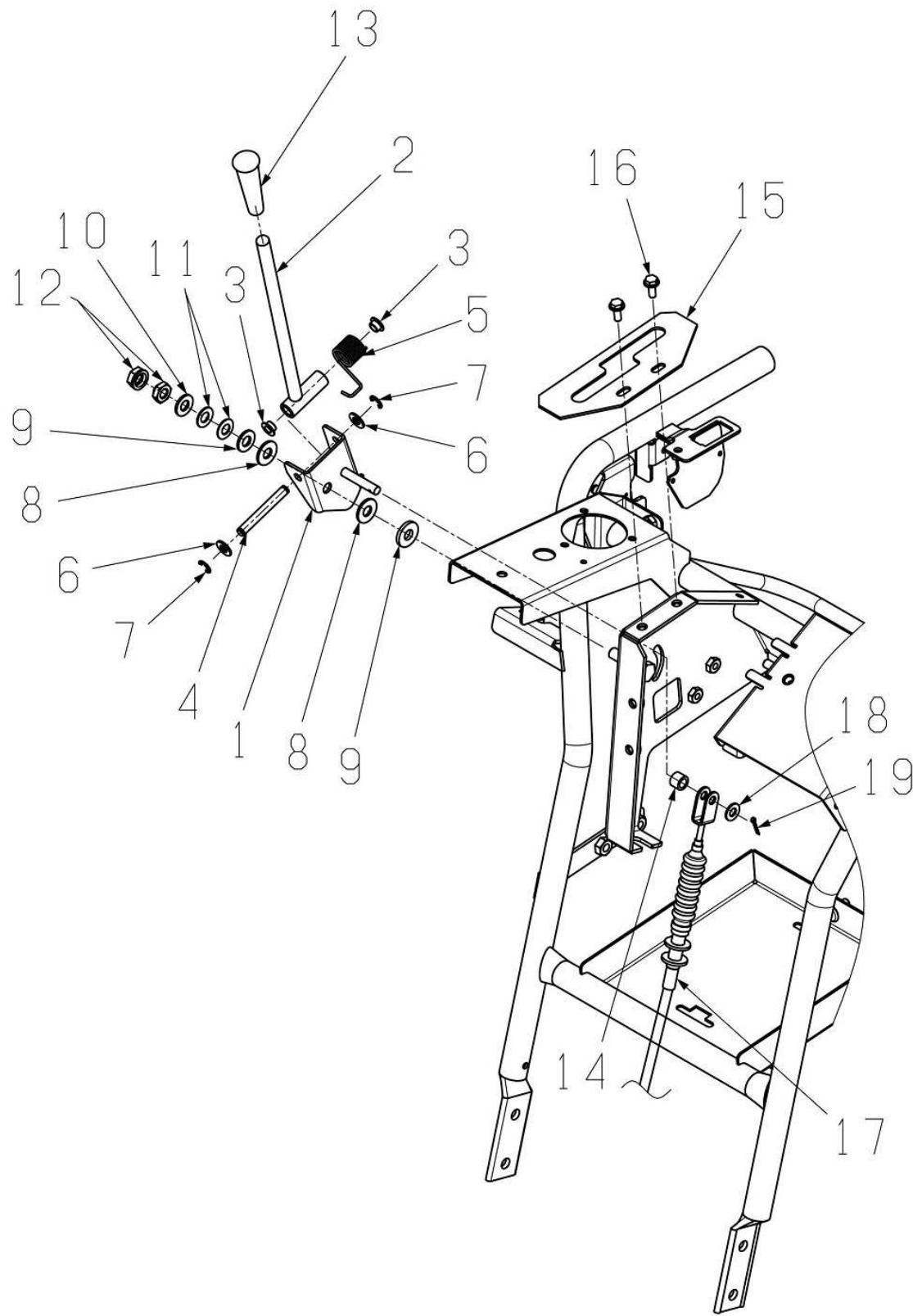

No	Product Number	Product Name	ST	Qty	Rev. Date	No
1	76700-B96-800	BRACKET COMP, SPEED SHIFTING LEVER	B2	1		7131
2	75200-B96-802	LEVER COMP, SPEED SHIFTING	B2	1		7132
3	91644-081580	BUSH, 80F-0815		2		7133
4	75901-B96-001	SHAFT,SPEED SHIFTING LEVER	M1	1		7134
5	75904-B96-000	SPRING		1		7135
6	94101-08010	WASHER, PLAIN 8		2		7136
7	94511-07010	RING, E 7		2		7137
8	91648-8010	WASHER, 80W-10		2		7138
9	91251-1025321	WASHER, RD 10×25×3.2	M1	2		7139
10	94101-10010	WASHER, PLAIN 10		1		7140
11	91252-102	WASHER, SPG H10		2		7141
12	91235-10100	NUT, HARD LOCK 10		1		7142
13	91731-1208014	GRIP, LEVER OH12		1		7143
14	08901-G01-000	COLLAR, 8×13.8×10	M1	1		7144
15	75903-B96-831	PLATE, GUIDE	B2	1		7145
16	93100-0601617	BOLT, FLANGE 6×16		2		7146
17	78700-B96-000	WIRE, MAIN SPEED SHIFTING		1		7148
18	94101-08010	WASHER, PLAIN 8		1		7149
19	94210-25150	PIN, SPLIT 2.5×15		1		7150

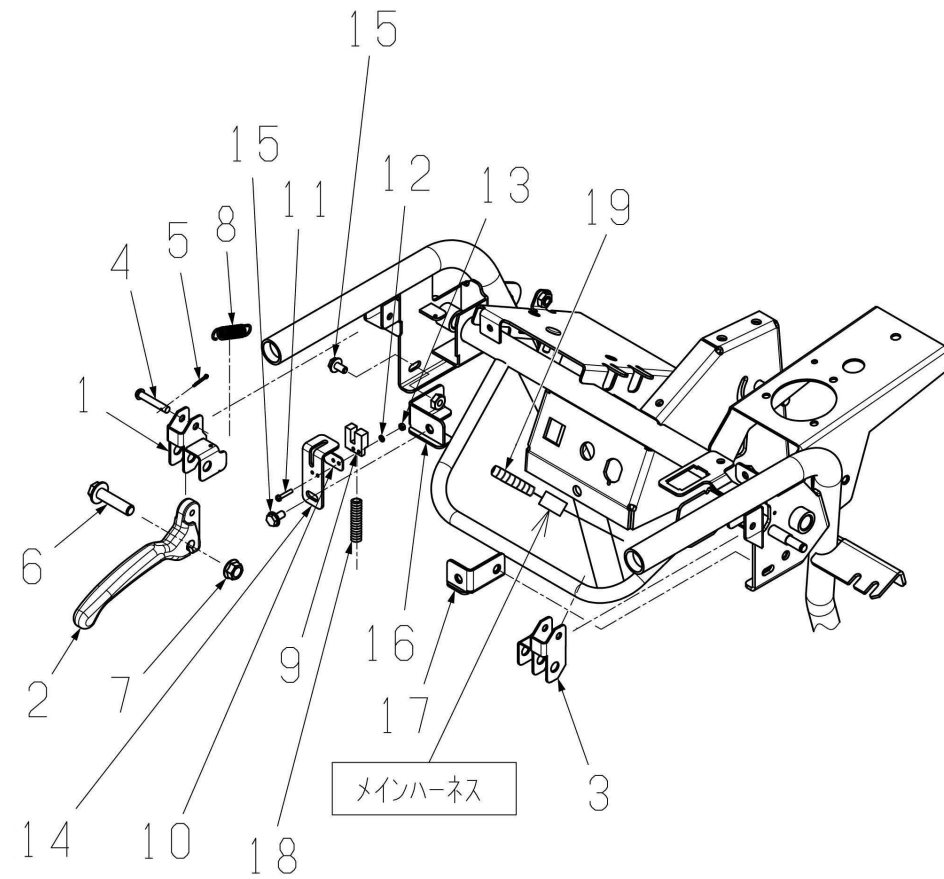

No	Product Number	Product Name	ST	Qty	Rev. Date	No
1	74600-B96-802	BRACKET L COMP, LEVER	B2	1		7201
2	74904-B96-001	LEVER, GRIP		2		7203
3	74700-B96-802	BRACKET R COMP, LEVER	B2	1		7204
4	94330-0603510	PIN, 6 × 35		2		7205
5	94210-20120	PIN, SPLIT 2 × 12		2		7207
6	93300-1004017	BOLT, FLANGE 10 × 1.25 × 40		2		7208
7	91237-1011	NUT, FLANGE U 10 × 1.25		2		7209
8	91606-B96-000	SPRING, COIL 8.8 × 40	M1B	2		7210
9	83300-B56-030	SWITCH, REED		2		7215
10	73908-B56-000	BASE, SWITCH 1.2	M1	2		7216
11	93500-0301614	SCREW, PAN 3 × 16		4		7217
12	94111-03012	WASHER, SPG 3		4		7218
13	94001-03412	NUT, 3		4		7219
14	78909-B96-801	BASE, SWITCH	B2	2		7220
15	93100-0601217	BOLT, FLANGE 6 × 12		4		7221
16	74200-B96-830	BRACKET L COMP, SWITCH	B2	1		7223
17	74300-B96-831	BRACKET R COMP, SWITCH	B2	1		7224
18	91382-0501201	CORRUGATE 5 × 120		2		7226
19	91382-0700801	CORRUGATE 7 × 80		1		7227

No	Product Number	Product Name	ST	Qty	Rev. Date	No
1	75902-B96-801	LEVER, THROTTLE	B2	1	Δ 1 2026/01/08	7301
2	75907-B18-000	KNOB, THROTTLE LEVER		1		7302
3	75908-B18-001	SCREW, SPECIAL 4×8		1		7303
4	77901-BA2-801	PLATE, THRUST	B2	1		7304
5	91251-0825321	WASHER, RD 8×25×3.2	M1	1		7305
6	91252-082	SPRING H, PLATE 8		2		7306
7	94001-08412	NUT, 8		2		7308
8	77800-B96-030	WIRE, THROTTLE		1		7309
9	78600-B96-001	WIRE, CHOKE		1		7310
10	91382-0504701	CORRUGATE 5×470		1		7311

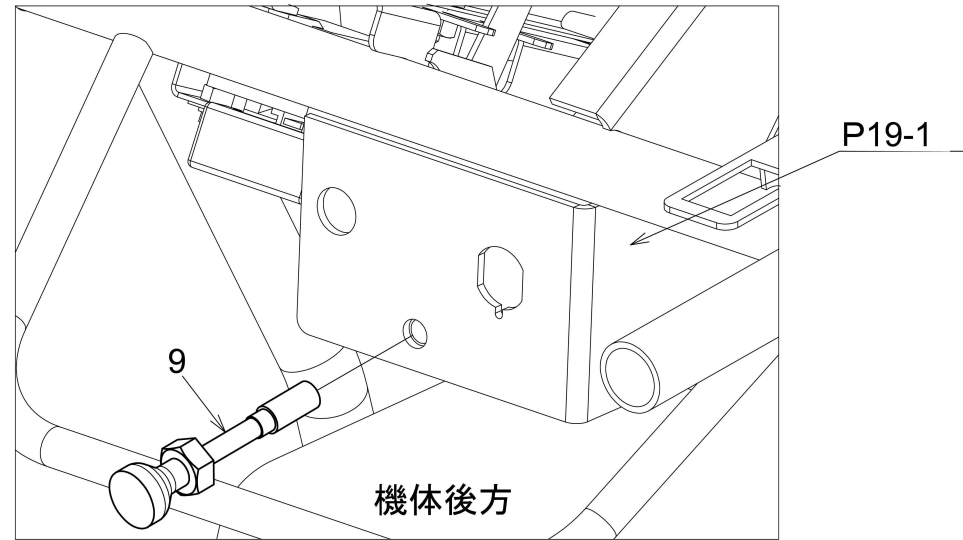
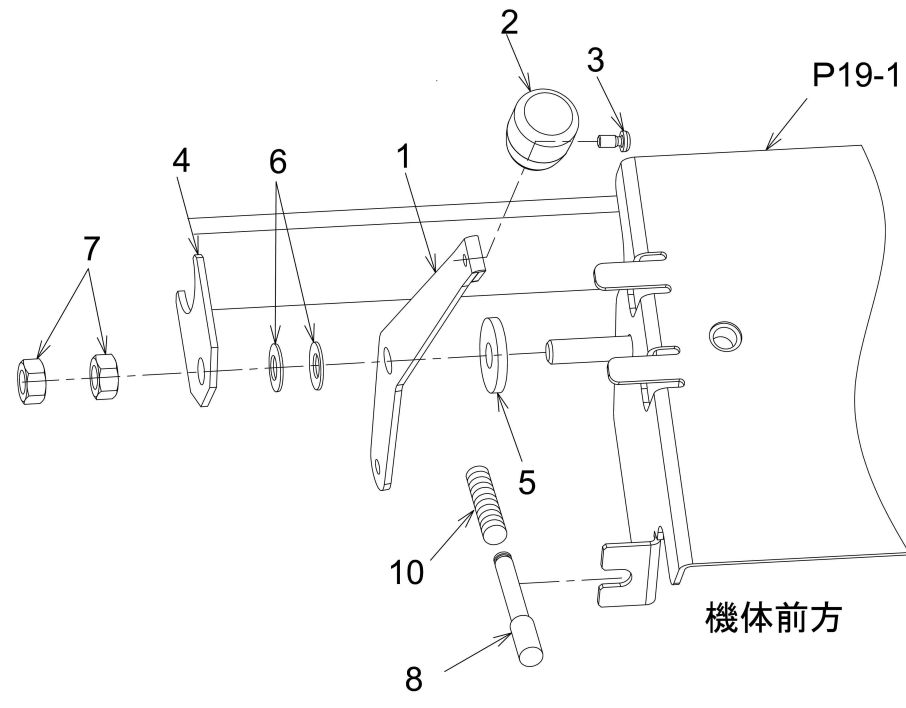

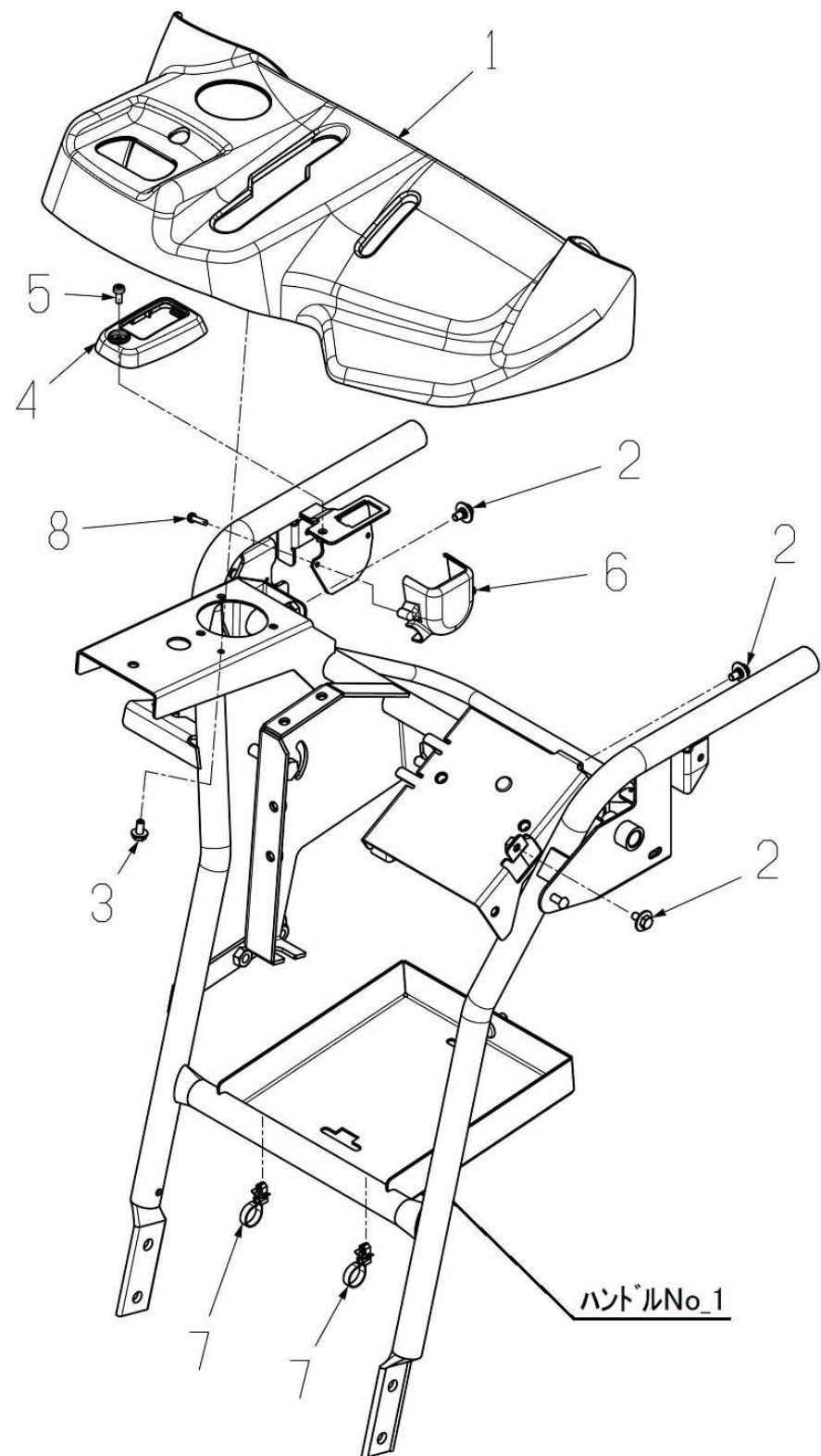

No	Product Number	Product Name	ST	Qty	Rev. Date	No
1	78800-B96-001	PANEL, CONTROL		1	Δ 1 2026/01/29	7401
2	48905-B96-000	BOLT, SHOULDER 6 × 9	M0	3		7402
3	93100-0501217	BOLT, FLANGE 5 × 12		1		7403
4	78904-B96-000	COVER, LIFTING SWITCH		1		7405
5	93500-0501257	SCREW 5 × 12		1		7406
6	78904-BA2-002	COVER, LIFTING SWITCH		1		9408
7	91314-119P7	STRAP, CABLE 1-19P7		2		9409
8	93901-M92-000	TAPTITE P, 4 × 12		2		9410

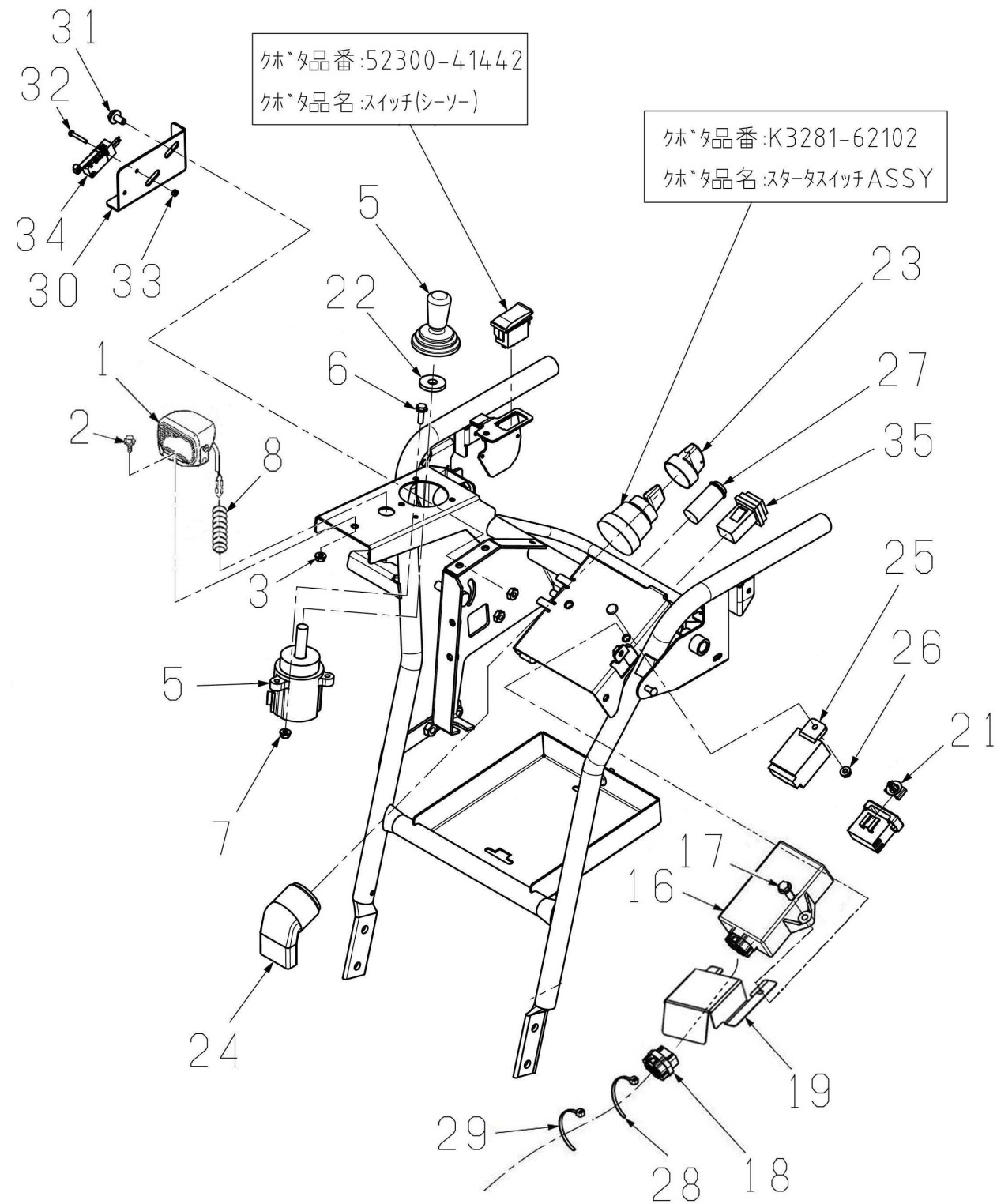

No	Product Number	Product Name	ST	Qty	Rev. Date	No
1	83100-G18-000	LAMP, 18W		1		8001
2	93100-0801617	BOLT, FLANGE 8 × 16		1		8002
3	94002-08410	NUT, FLANGE 8		1		8003
5	83200-B18-000	SWITCH, CONTROL		1		8005
6	93100-0602017	BOLT, FLANGE 6 × 20		3		8006
7	94002-06410	NUT, FLANGE 6		3		8007
8	91382-0700801	CORRUGATE 7 × 80		1		8008
11	-					8024
16	84500-B96-003	ECU DX		1	Δ 1 2025/09/16	8018
17	93100-0802517	BOLT, FLANGE 8 × 25		2		8019
18	85100-BA2-003	HARNESS DX, MAIN		1		8020
19	71908-B96-801	COVER, ECU	B2	1		8036
21	81902-BA2-000	CLIP, COUPLER HOLDER		1		8023
22	83902-B18-000	WASHER, RD 11 × 32 × 4.5	M1	1		8025
23	88901-B82-000	COVER, KEY		1		8026
24	88902-B81-030	COVER, KEY SWITCH		1		8027
25	84200-B88-000	RELAY, CHUTE		1		8029
26	94002-06410	NUT, FLANGE 6		1		8030
27	89100-A62-000	LAMP UNIT, PILOT		1		8031
28	91310-150	BAND, PRT1.5S		8		8033
29	91310-300	BAND, PRT3S		11	Δ 1 2025/03/11	8034
30	77903-B96-800	BRACKET COMP, SENSOR	B2	1		8040
31	93100-0601217	BOLT, FLANGE 6 × 12		2		8041
32	83901-B10-000	BOLT, SL M3 × 20		2		8042
33	94001-03412	NUT, 3		2		8043
34	83100-B10-000	SWITCH, CHUTE		1		8044
35	83100-B96-000	SWITCH, WATRTPROOF LIGHT		1		8032

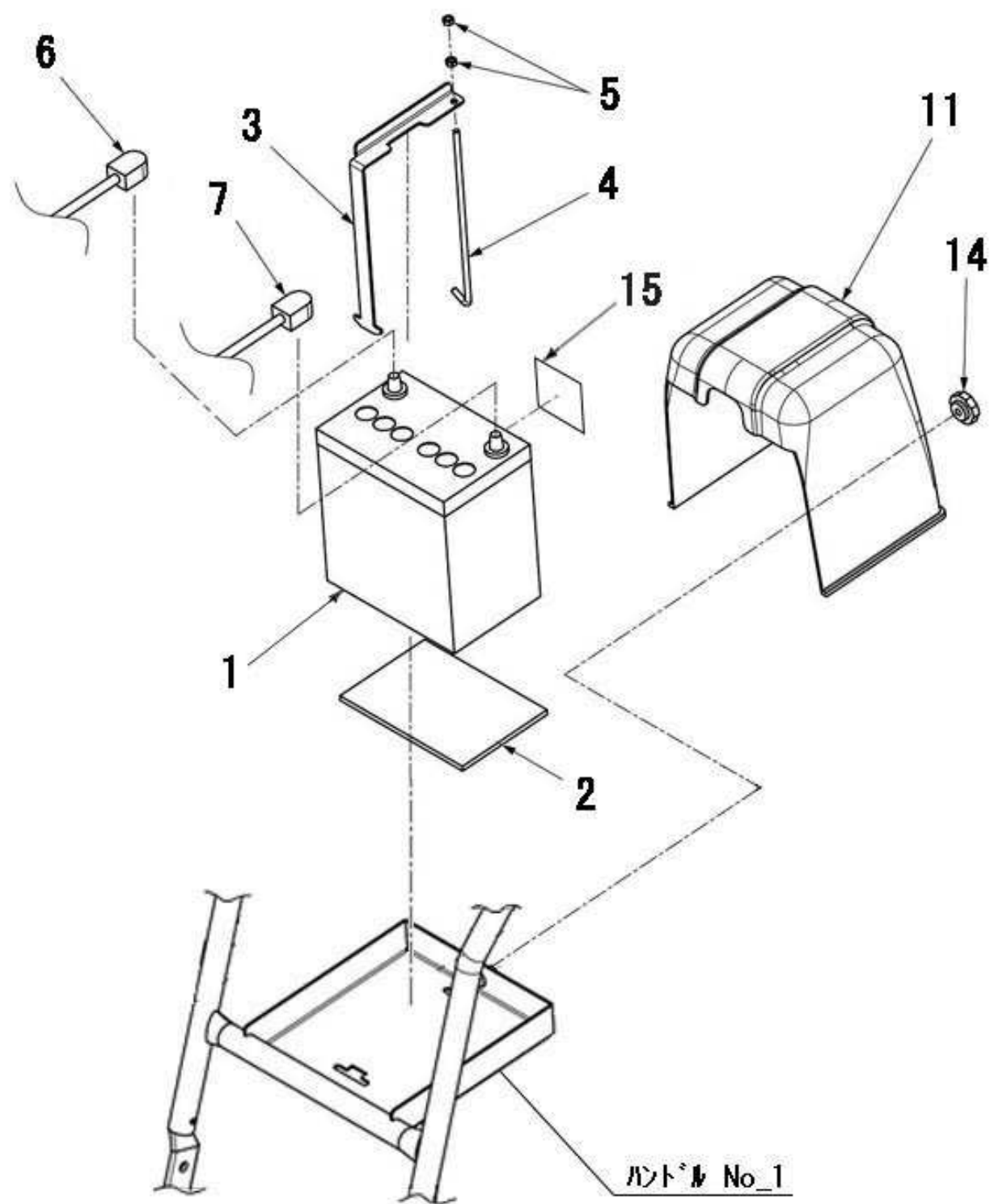

No	Product Number	Product Name	ST	Qty	Rev. Date	No
1	91890-040B19L	BATTERY, 40B19L		1		8009
2	89902-M56-002	RUBBER, ANTIVIBRATION		1		8010
3	86901-BA2-800	CLAMP, BATTERY	B2	1		8011
4	86902-B96-000	BOLT, BATTERY SET	M1	1		8012
5	94001-06412	NUT, 6		2		8013
6	87100-BA2-000	CORD (+), BATTERY 1100		1		8021
7	87200-B96-030	CORD (-), BATTERY 900		1		8022
11	88906-B96-031	COVER, BATTERY		1		8014
14	91242-0821	NUT, KNOB 8		1		8015
15	91193-018	LABEL, BATTERY DANGER		1		8016

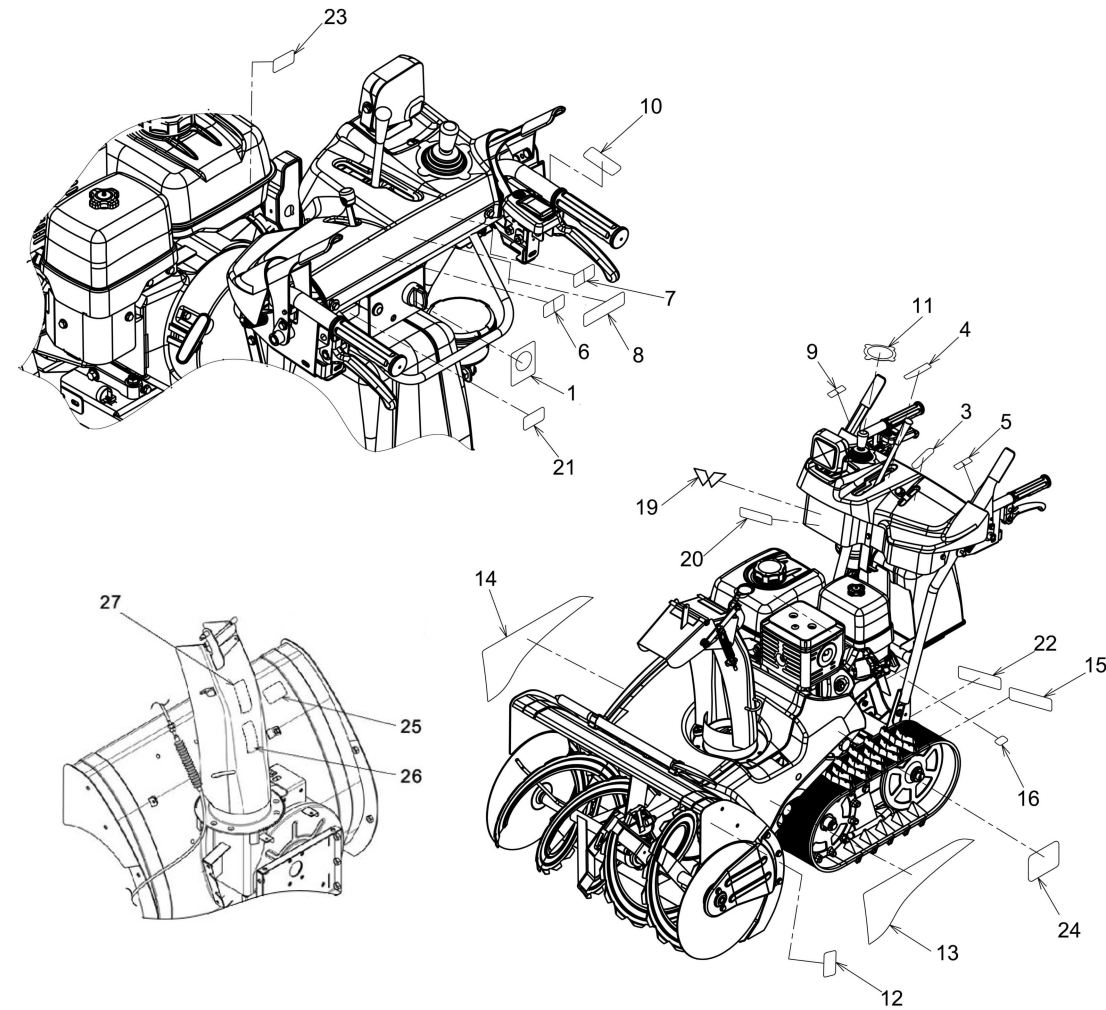

No	Product Number	Product Name	ST	Qty	Rev. Date	No
1	79902-BA1-000	MARK, ENGINE SWITCH		1		9101
3	79903-B96-002	MARK, THROTTLE		1		9103
4	79904-B96-003	MARK, SPEED SHIFTING		1		9104
5	79933-B96-000	MARK, TRAVEL CLUTCH		1		9105
6	79934-B96-000	MARK L, SIDE CLUTCH		1		9106
7	79935-B96-000	MARK R, SIDE CLUTCH		1		9107
8	79946-B96-000	LABEL, WARNING		1		9007
9	79928-B96-000	MARK, AUGER CLUTCH		1		9108
10	79937-B96-000	MARK, AUGER HEIGHT		1		9109
11	79910-B96-004	MARK, CHUTE		1		9110
12	79941-B96-000	LABEL, BELT COVER CAUTION		2		9005
13	79922-B96-002	MARK L, SXC1280E		1	Δ 1 2024/12/17	9111
14	79923-B96-002	MARK R, SXC1280E		1	Δ 1 2024/12/17	9112
15	79945-B96-000	MARK, CE (SXC1280E)		1		9113
16	79928-B56-000	LABEL, MUFLLER CAUTION		1		4112
17	79944-B96-000	MARK, BACK AUTO LIFT		1		9201
18	-					9202
19	79912-B97-001	MARK, WADO		1		9115
21	79938-B96-000	MARK, FUSE		1		9116
22	79910-BA3-002	MARK, WADO PbH		2		9117
22	91907-001	-		1		9203
23	79940-B96-001	MARK, NOISE		1		9114
25	91193-015	LABEL, AUGER DANGER		1		9001
26	91194-017	LABEL, DISCHARGE WARNING		1		9003
27	91194-018	LABEL, BLOWER WARNING		1		9004

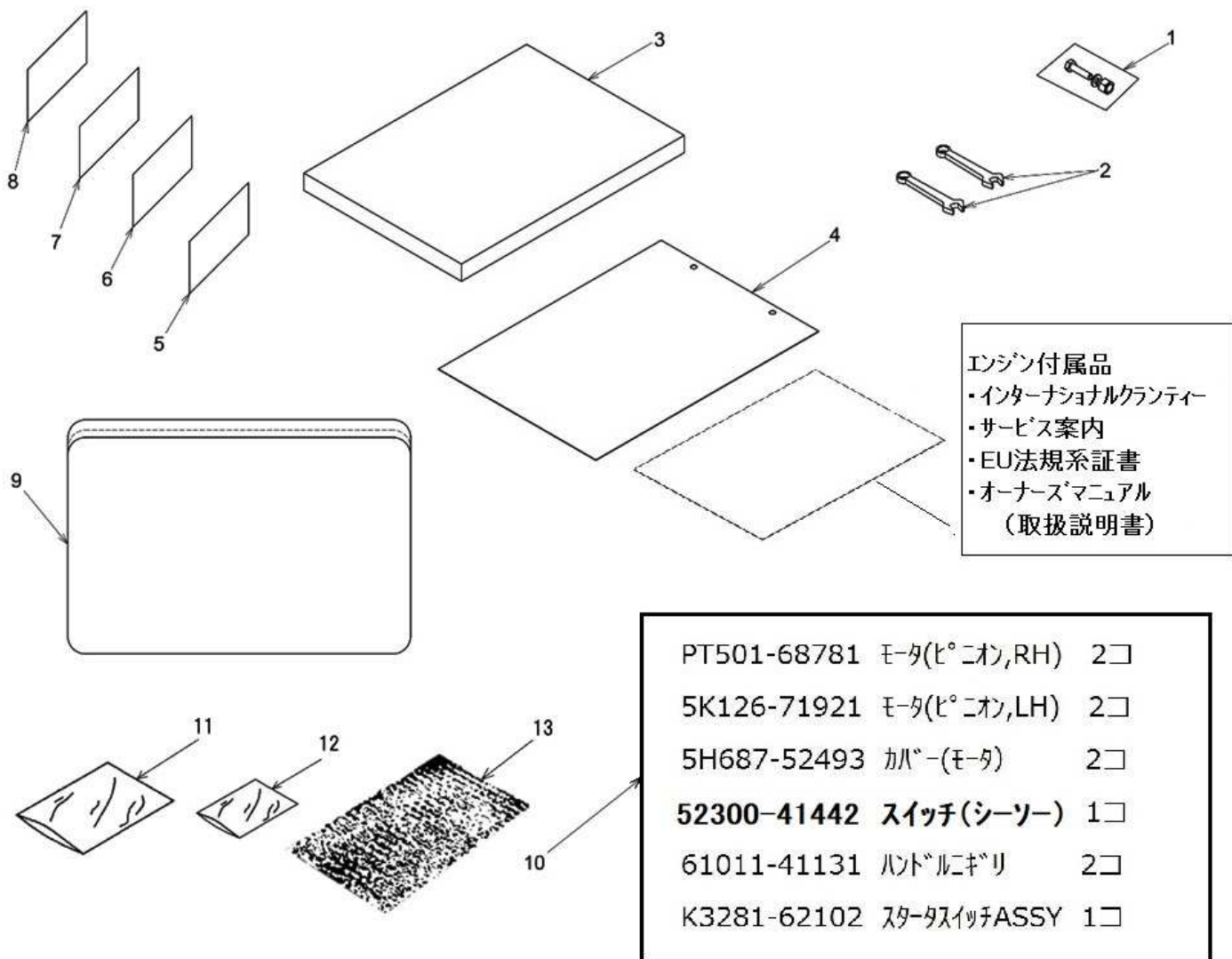

No	Product Number	Product Name	ST	Qty	Rev. Date	No
1	90001-B96-004	BOLT ASSY, SHEAR 6×25		1		9301
2	91905-B56-000	WRENCH 10, COMBINATION		2		9302
3	91906-B96-090	INSTRUCTION MANUAL		1		9303
4	91903-001	CERTIFICATE, INSPECTION PASS		1		9304
5	91811-105	FUSE, BLADE 5A		1		9306
6	91811-110	FUSE, BLADE 10A		1		9307
7	91811-125	FUSE, BLADE 25A		1		9308
8	91811-130	FUSE, BLADE 30A		1		9309
9	90002-B96-000	CASE, TOOL		1		9411
10	L6161-0U000	PARTS KIT, SXC1070		1		9404
11	91998-031215	BAG, POLY 0.03×120×150		1		9414
12	91998-030812	BAG, POLY 0.03×80×120		1		9415
13	91997-240325	BAG, AIR CUSHION 240×325		2		9416